

# DECK LAYOUT

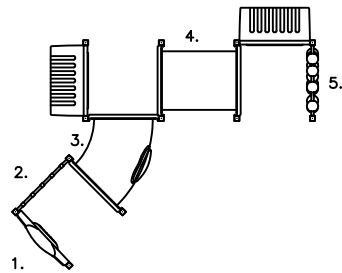

GROUND LEVEL

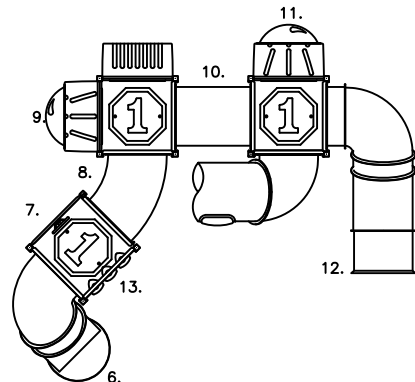

1100 LEVEL

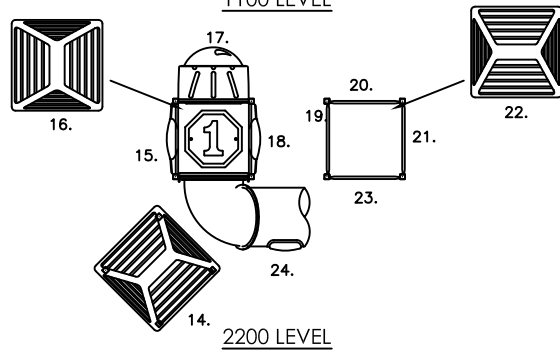

2200 LEVEL

## LEGEND

1. VILLAGE COUNTER PANEL
2. SQUEEZE BARS
3. 45° CRAWL TUBE & BUBBLE
4. 1M CRAWL TUBE
5. ABACUS PANEL
6. 90° TUBE CLIMBER
7. JAIL BAR PANEL & WHEEL
8. 45° CRAWL TUBE
9. TOWER CLIMBER & BUBBLE
10. 1M CRAWL TUBE
11. TOWER CLIMBER & BUBBLE
12. 1100 TUBE SLIDE
13. NAUGHTS & CROSSES PANEL
14. VILLAGE ROOF
15. VILLAGE WINDOW PANEL
16. VILLAGE ROOF
17. TOWER CLIMBER & BUBBLE
18. VILLAGE WINDOW PANEL
19. 1/2 JAIL BAR PANEL
20. 1/2 JAIL BAR PANEL
21. 1/2 JAIL BAR PANEL
22. VILLAGE ROOF
23. 1/2 JAIL BAR PANEL
24. DK-DK TUBE CLIMBER & BUBBLE

# CTU-105 'TYKES TOWER'

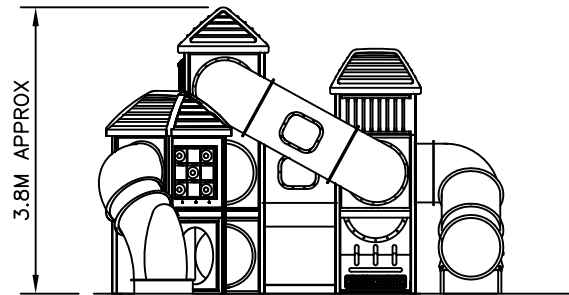
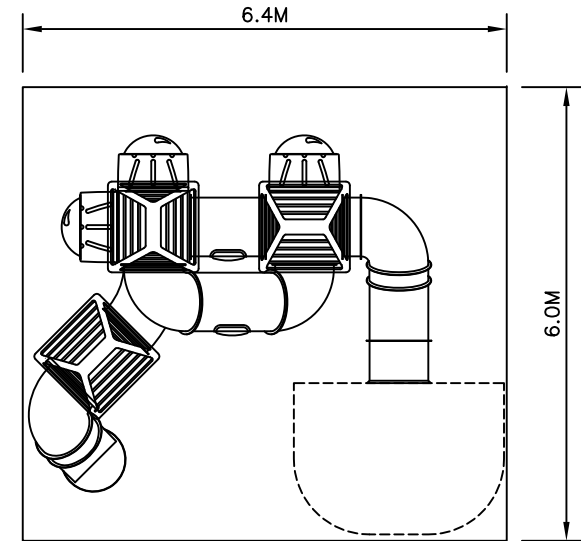

SCALE = mm



APPROX AREA (sq.m.): 38.4 APPROX PERIMETER (lin.m.): 24.8

----- INDICATES SLIDE EXIT SAFETY AREA  
 \_\_\_\_\_ INDICATES RECOMMENDED AREA

CTU-105: TYKES TOWER  
 CONTAINED UNIT  
 STANDARD DRAWING

DRAWING No.:CTU-105		REV: B	
DRN:	LB	SCALE 1:100	SIZE
DATE: 01/05/15		SHEET 1 OF 1	A4

- Heights above Playground surface are shown on decks and all play equipment. is. Ⓢ= 400mm
- Impact absorbing ground cover is required under and around all play equipment.
- The min. recommended fall zone around the entire play structure is shown. This zone is to be free of all tripping or collision hazards (ie. roots, rocks, border material, etc).
- Site layout and dimensions are subject to verification prior to installation.
- Dimensions in millimetres unless stated otherwise.



DO NOT SCALE