

# DYNAMIC GROUP / SILVER SERIES

DGSS 101



## Product Information

Dimensions (L x W x H)	: 4,55 x 4,15 x 2,85m
Age Group	: 7+
Capacity	: 17
Fall Height	: 2,7 m
Safety Area	: 46,7 m <sup>2</sup>



## SILVER SERIES

The Silver Series is a series of non-platform play equipment for children aged +7, featuring intensive and challenging balance and climbing units and multiple play stations. Inspired by the marine theme, multifunctional units are designed in a modular way and provide easy installation. The purpose of the Silver Series, which is designed by moving away from the ordinary game park logic; is that children discover different uses of the units, come up with their own play to play with it and challenge their imagination while learning to control their movements.

DISTRIBUTED BY



1300 433 364







**Metal parts are comprised of ST 37 Steel with a 3-step metal finish. Sandblasting and solvent-free zinc primer coating and electrostatic powder paint application is inherently corrosion resistant under extreme weather conditions and UV.**



**UV resistant with high value of light fastness rotomolded polyethylene parts are used to form the structure. All parts are manufactured with double wall technique with the thickness between 4-6 mm.**



**High quality panels made of HDPE panels are milled to provide a smooth, gently rounded edge. The thickness of the panels varies according to its purpose for floors, roofs, and walls.**



**CmrRope™ is formed by 6 strands of galvanized wires and a core either steel or fiber. Each strand is tightly braided with Polyester which is adhered to galvanized wires with a patented method to create a solid surface where polyester meets with wires. So extra protection is achieved against friction and vandalism. Surface is extremely abrasion and UV resistant also fire retardant.**



**Single-casing aluminum cast connectors are compressed with 300 tons to avoid moving and premature wear. "E (end stop) connector" is shape-ly and pleasant to grip with no sharp angles or edges. These connectors are fastened to main frame either to welded flanges on main frame or with "C" aluminum clamps to main frame.**



**Modular connectors eliminate the need for welding during assembly. Root disc is made using aluminum injection technique and has 6 connection points. Used connection points are also made using the aluminum injection technique and non-used connection points are covered with PA6 material.**





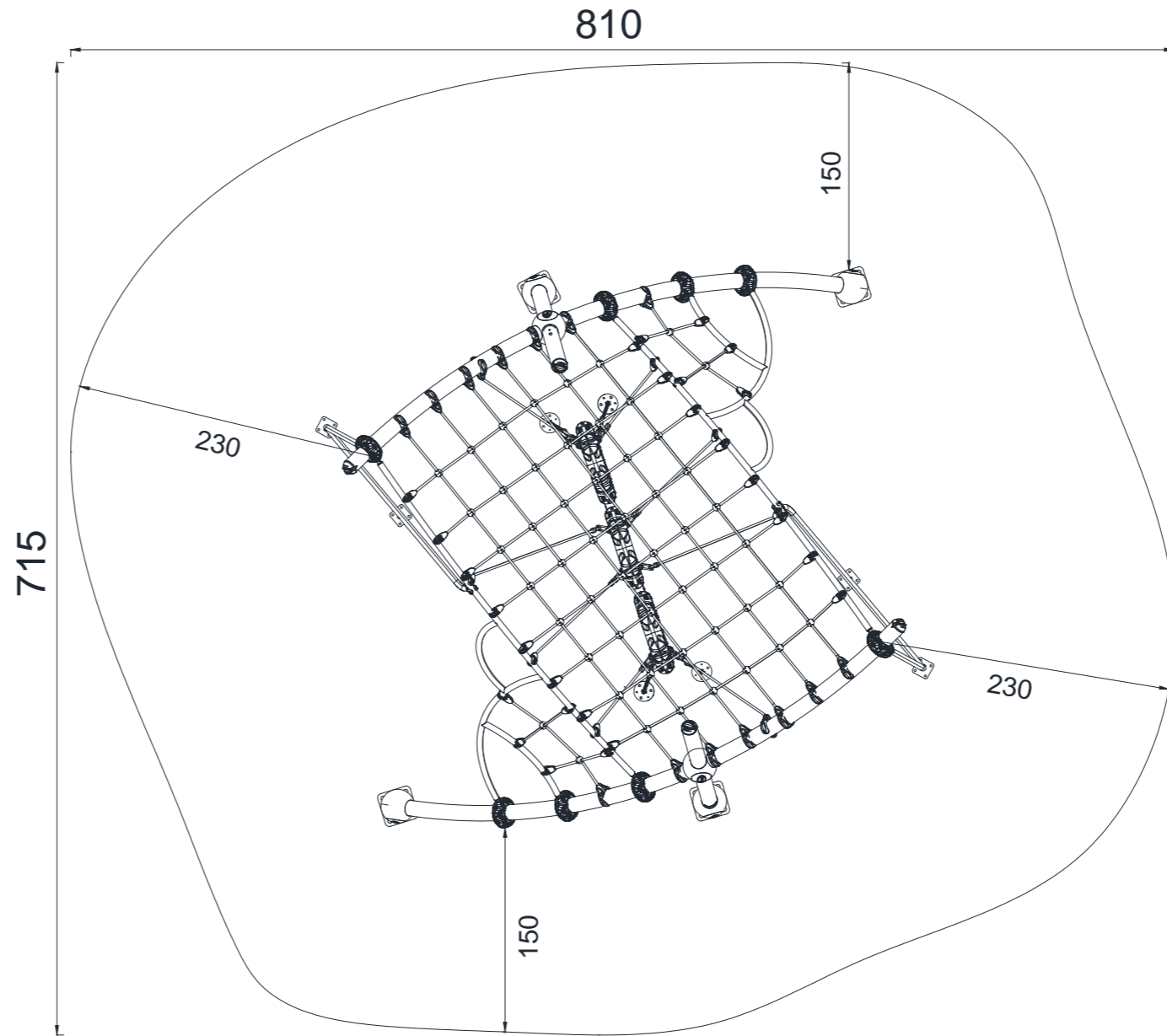

TOP VIEW

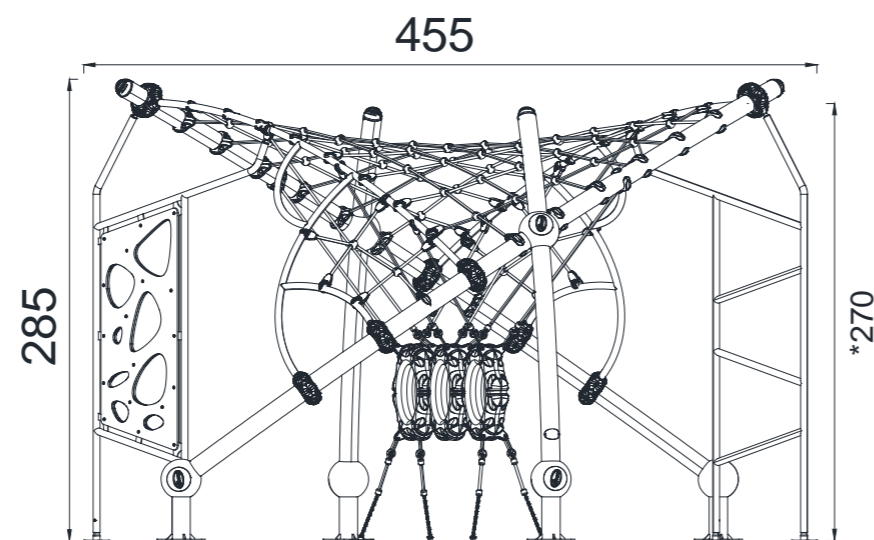

FRONT VIEW

Maximum Fall Height / Dimensions shown are in cm

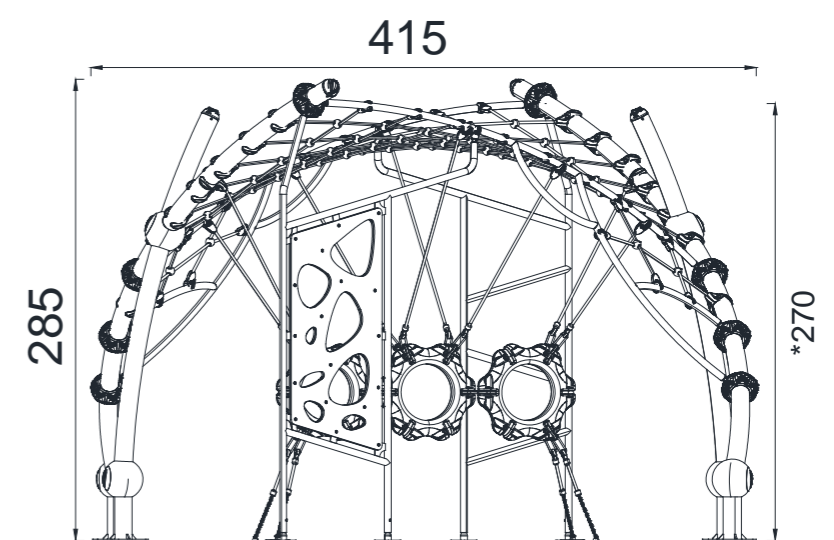

SIDE VIEW



## BOUNCING

To bounce is the act of bouncing on a responsive, flexible, elastic or tensile surface.



## SLIDE

To slide is the act of moving fast downwards steady on a slide.



## BALANCE

To balance is to stay upright when walking or standing on a surface that makes this challenging.



## ROCK

To rock is the action of rocking back and forth, or sideways, on e.g. a piece of spring equipment.



## SITTING

It is an area where children can rest while sitting and have fun.



## SWING

To swing is the movement of swinging back forth, or in circular movement, seated, standing or lying, in an unhindered arc.



## HANGING

To hang in arms is the act of carrying the body with the hands or arms, possible to traverse to another platform or play item.



## SPIN

To spin involves a fast, repeating horizontal or vertical turn of the body on a piece of equipment that facilitates social interaction.



## CLIMBING

To climb is the act of moving upwards, cross coordinating arms and legs, on a vertical or inclined surface or net.



## CRAWLING

To crawl is the movement of moving forwards or backwards, cross-coordinating arms and legs, on a horizontal or slightly incline surface



## RUNNING

Running is an activity that encourages children to interact with the playgroup by running and develop physically.



## ACCESSIBLE

These are special areas where children with disabilities can play and have fun and without feeling different.



## INTERACTION

It is children's communicating with the play group by touching and feeling.



## ROTATE

To rotate involves a vertical or horizontal slower paced turn of the body, facilitated by a piece of equipment.



## EQUALITY

Equality is the feature of the playgroup to attract the attention of all children, regardless of gender.



## SOCIALIZE

To socialize is the act of meeting, communicating or cooperating in an activity that stimulates and facilitates social interaction.



## ROLE PLAY

Role play is motivated through play items that stage a frame, place or environment for acting out make believe or role play scenarios.



## PULL

To pull is the act of pulling item towards you or you towards an item with one or both hands, or possibly with the entire body.



## PULL

To glide is the act of moving from one point to another without shifting the feet, in a horizontal or vertical movement in a seated, lying or standing position, letting gravity do the work.



## PUSH

To push is the act of pushing an item away from you with one or both hands, possibly with the entire body.