

GEO GROUP / **WITCH SERIES**

GGWS 1002

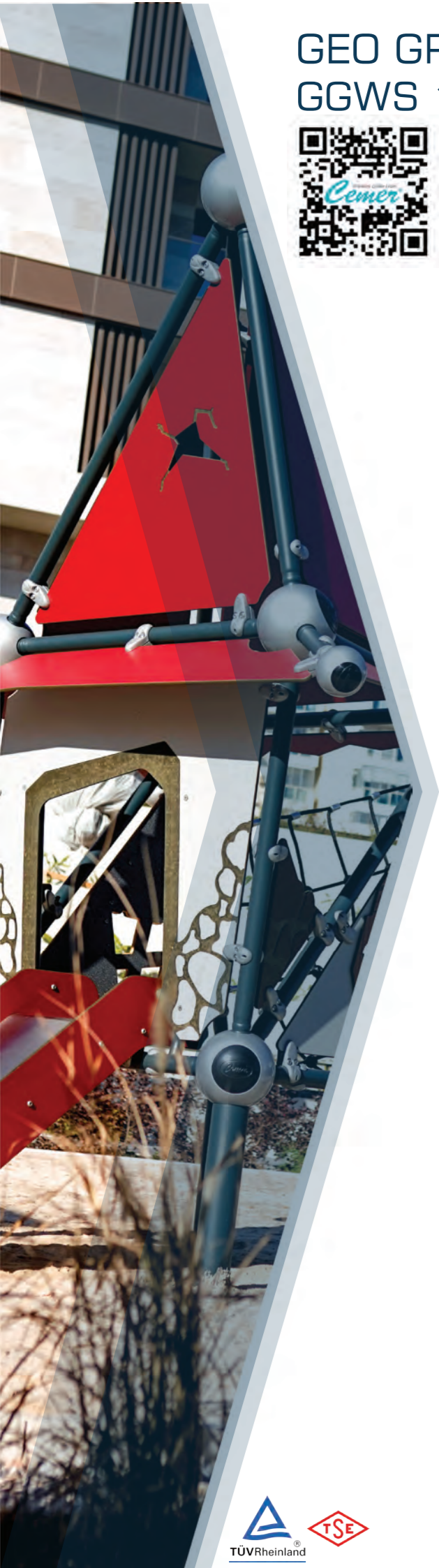

Product Information

Dimensions (L x W x H)	: 3,35 x 3,55 x 3,7m
Age Group	: 2+
Capacity	: 8
Fall Height	: 0,95 m
Safety Area	: 33,3 m <sup>2</sup>



## WITCH SERIES

Witch Series is a product group based on the climbing function which plays a major role in children's physical and mental development. It aims to attract children's curiosity to discover thus witch theme and witch house concepts were used for this purpose. In order to create the sensation of a witch house, the graphics on the product are designed and produced in a way to support the theme.

DISTRIBUTED BY



1300 433 364





Single-casing aluminum cast spheres with anticorrosion treatment are placed at junctions. These spheres are designed with integrated bedding for connecting pipes.

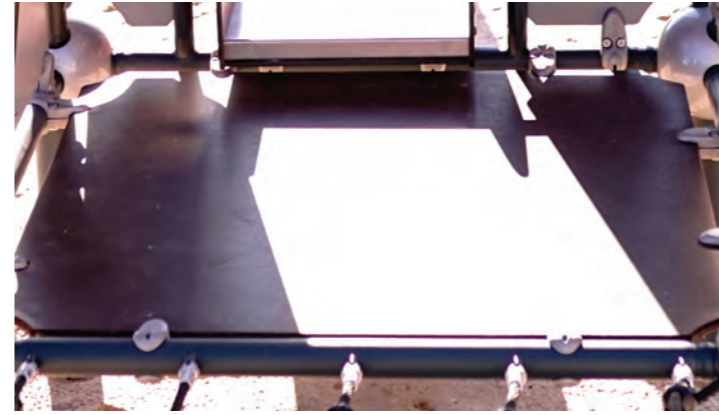

Durable and weatherproof laminated Plywood is used at platforms. These platforms have ability of anti-slip feature to increase the safety of the users.



Metal parts are comprised of ST 37 Steel with a 3-step metal finish. Sandblasting and solvent-free zinc primer coating and electrostatic powder paint application is inherently corrosion resistant under extreme weather conditions and UV.



CmrRope™ is formed by 6 strands of galvanized wires and a core either steel or fiber. Each strand is tightly braided with Polyester which is adhered to galvanized wires with a patented method to create a solid surface where polyester meets with wires. So extra protection is achieved against friction and vandalism. Surface is extremely abrasion and UV resistant also fire retardant.



High quality panels made of HPL panels are milled to provide a smooth, gently rounded edge. The thickness of the panels varies according to its purpose for floors, roofs, and walls. These panels are connected to steel pipes or profiles with cast aluminum panel clamps or flanges. To increase the visibility of interior of the equipment, some panels are equipped with 5 mm thick anti-climb steel mashes. This wire mash is placed within either steel or HPL frame.



This slide type is very resistant to wear and tear remaining in mint condition for years. Stainless steel material is 2 mm thick. Approved product according to EN 1176 norms. Sides of the slide is HPL or HDPE with rounded edges.

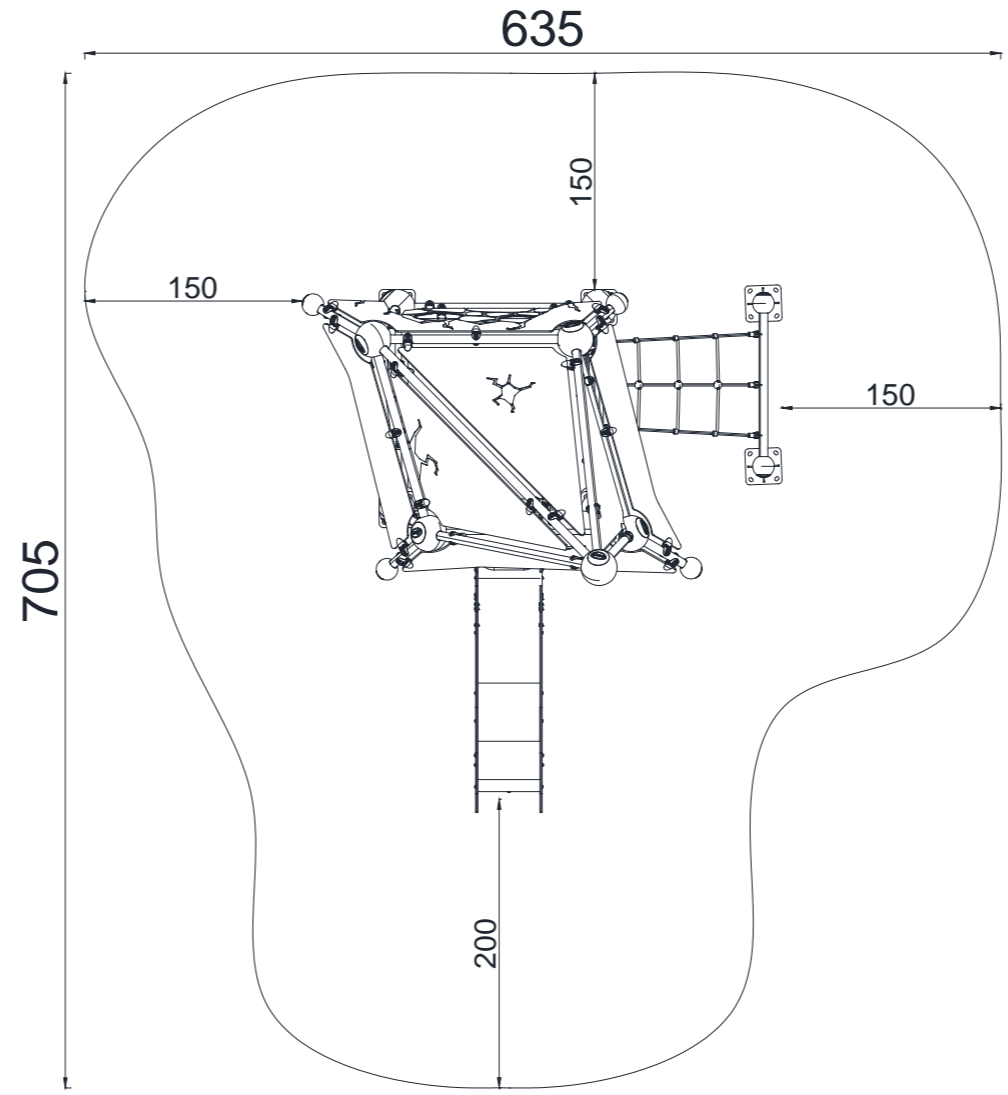

TOP VIEW

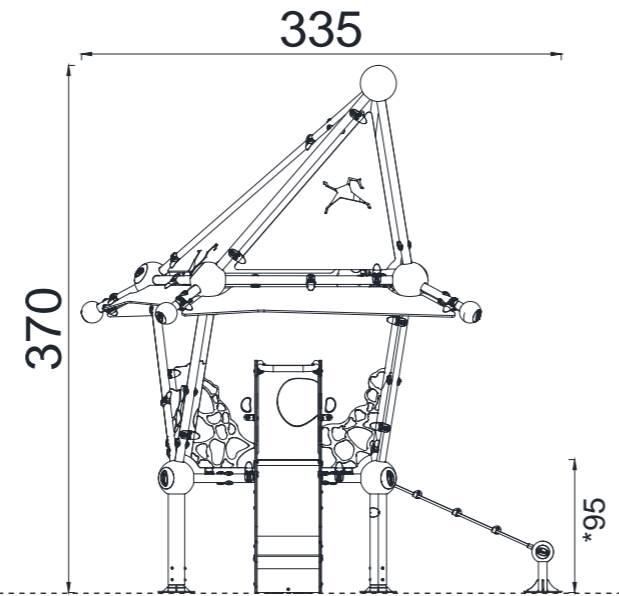

FRONT VIEW

Maximum Fall Height / Dimensions shown are in cm

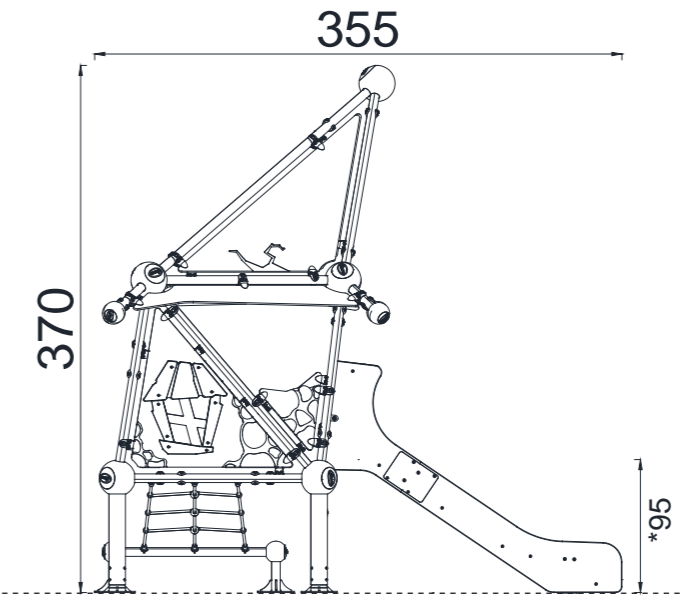

SIDE VIEW



### BOUNCING

To bounce is the act of bouncing on a responsive, flexible, elastic or tensile surface.



### SLIDE

To slide is the act of moving fast downwards steady on a slide.



### BALANCE

To balance is to stay upright when walking or standing on a surface that makes this challenging.



### ROCK

To rock is the action of rocking back and forth, or sideways, on e.g. a piece of spring equipment.



### SITTING

It is an area where children can rest while sitting and have fun.



### SWING

To swing is the movement of swinging back forth, of in circular movement, seated, standing or lying, in an unhindered arc.



### HANGING

To hang in arms is the act of carrying the body with the hands or arms, possible to traverse to another platform or play item.



### SPIN

To spin involves a fast, repeating horizontal or vertical turn of the body on a piece of equipment that facilitates social interaction.



### CLIMBING

To climb is the act of moving upwards, cross coordinating arms and legs, on a vertical or inclined surface or net.



### CRAWLING

To crawl is the movement of moving forwards or backwards, cross-coordinating arms and legs, on a horizontal or slightly incline surface



### RUNNING

Running is an activity that encourages children to interact with the playgroup by running and develop physically.



### ACCESSIBLE

These are special areas where children with disabilities can play and have fun and without feeling different.



### INTERACTION

It is children's communicating with the play group by touching and feeling.



### ROTATE

To rotate involves a vertical or horizontal slower paced turn of the body, facilitated by a piece of equipment.



### EQUALITY

Equality is the feature of the playgroup to attract the attention of all children, regardless of gender.



### SOCIALIZE

To socialize is the act of meeting, communicating or cooperating in an activity that stimulates and facilitates social interaction.



### ROLE PLAY

Role play is motivated through play items that stage a frame, place or environment for acting out make believe or role play scenarios.



### PULL

To pull is the act of pulling item towards you or you towards an item with one or both hands, or possibly with the entire body.



### GLIDE

To glide is the act of moving from one point to another without shifting the feet, in a horizontal or vertical movement in a seated, lying or standing position, letting gravity do the work.



### PUSH

To push is the act of pushing an item away from you with one or both hands, possibly with the entire body.