

SPIDER GRUP / **SPIDER GROUP**  
SGM 1033-P

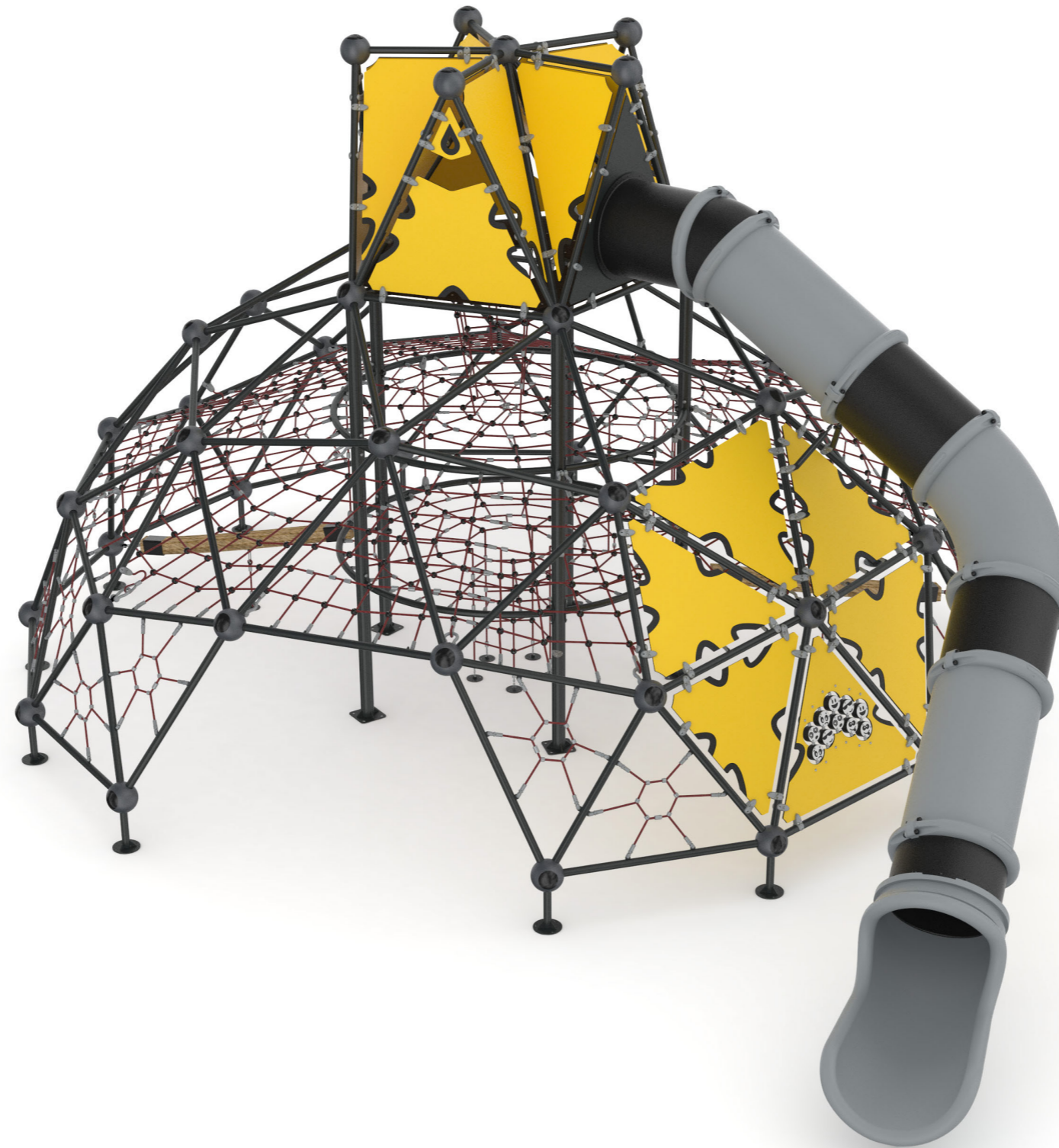

Product Information

Dimensions (L x W x H)	: 11,25 x 8,85 x 5,75m
Age Group	: 5+
Capacity	: 80
Fall Height	: 2,0 m
Safety Area	: 148 m <sup>2</sup>



# SPIDER GROUP

Spider Group takes you to the excitement of climbing and the peaks of entertainment. It was designed to allow children to experience the thrill of climbing while supporting improvement of the physical skills that will contribute to the development of the muscle-coordination system. It creates a target for children to climb, allows them to overcome fear of heights. It also contributes to the mental development of children while choosing the path they climb.

DISTRIBUTED BY



1300 433 364



# SPIDER GRUP / SPIDER GROUP

## SGM 1033-P



Metal parts are comprised of ST 37 Steel with a 3-step metal finish. Sandblasting and solvent-free zinc primer coating and electrostatic powder paint application is inherently corrosion resistant under extreme weather conditions and UV.



Single-casing aluminum cast spheres with anticorrosion treatment are placed at junctions. These spheres are designed with integrated bedding for connecting pipes.



Single-casing, injection manufactured connectors are used at the intersection points of ropes.



CmrRope™ is formed by 6 strands of galvanized wires and a core either steel or fiber. Each strand is tightly braided with Polyester which is adhered to galvanized wires with a patented method to create a solid surface where polyester meets with wires. So extra protection is achieved against friction and vandalism. Surface is extremely abrasion and UV resistant also fire retardant.



UV resistant with high value of light fastness rotomolded polyethylene parts are used to form the structure. All parts are manufactured with double wall technique with the thickness between 4-6 mm.

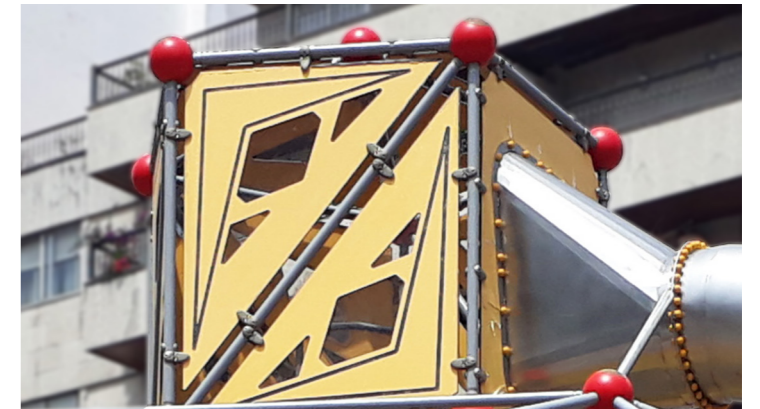

High quality panels made of HPL panels are milled to provide a smooth, gently rounded edge. The thickness of the panels varies according to its purpose for floors, roofs, and walls. These panels are connected to steel pipes or profiles with cast aluminum panel clamps or flanges.

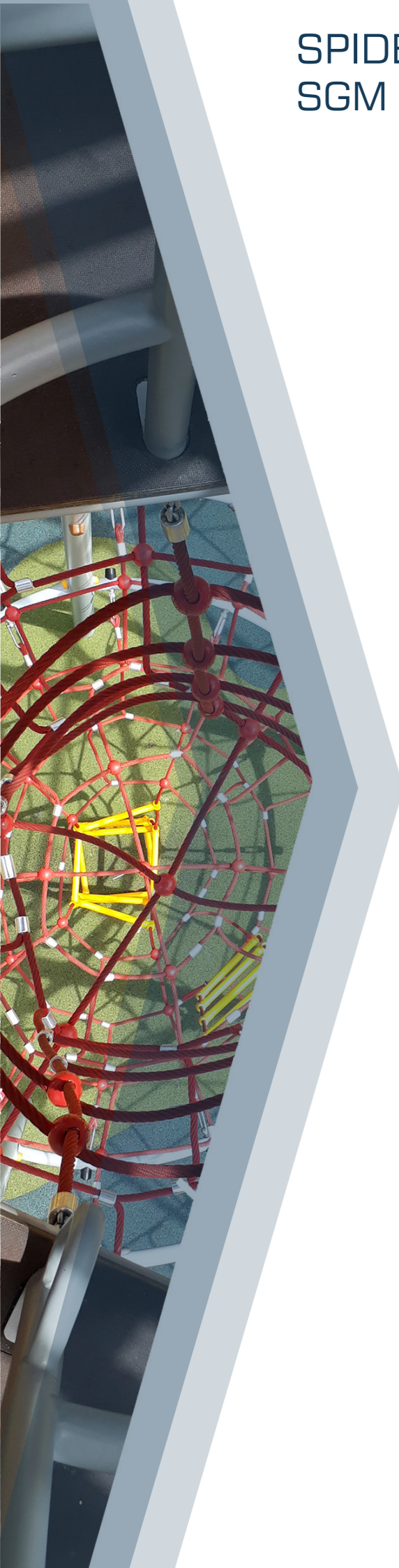

# SPIDER GRUP / SPIDER GROUP

## SGM 1033-P

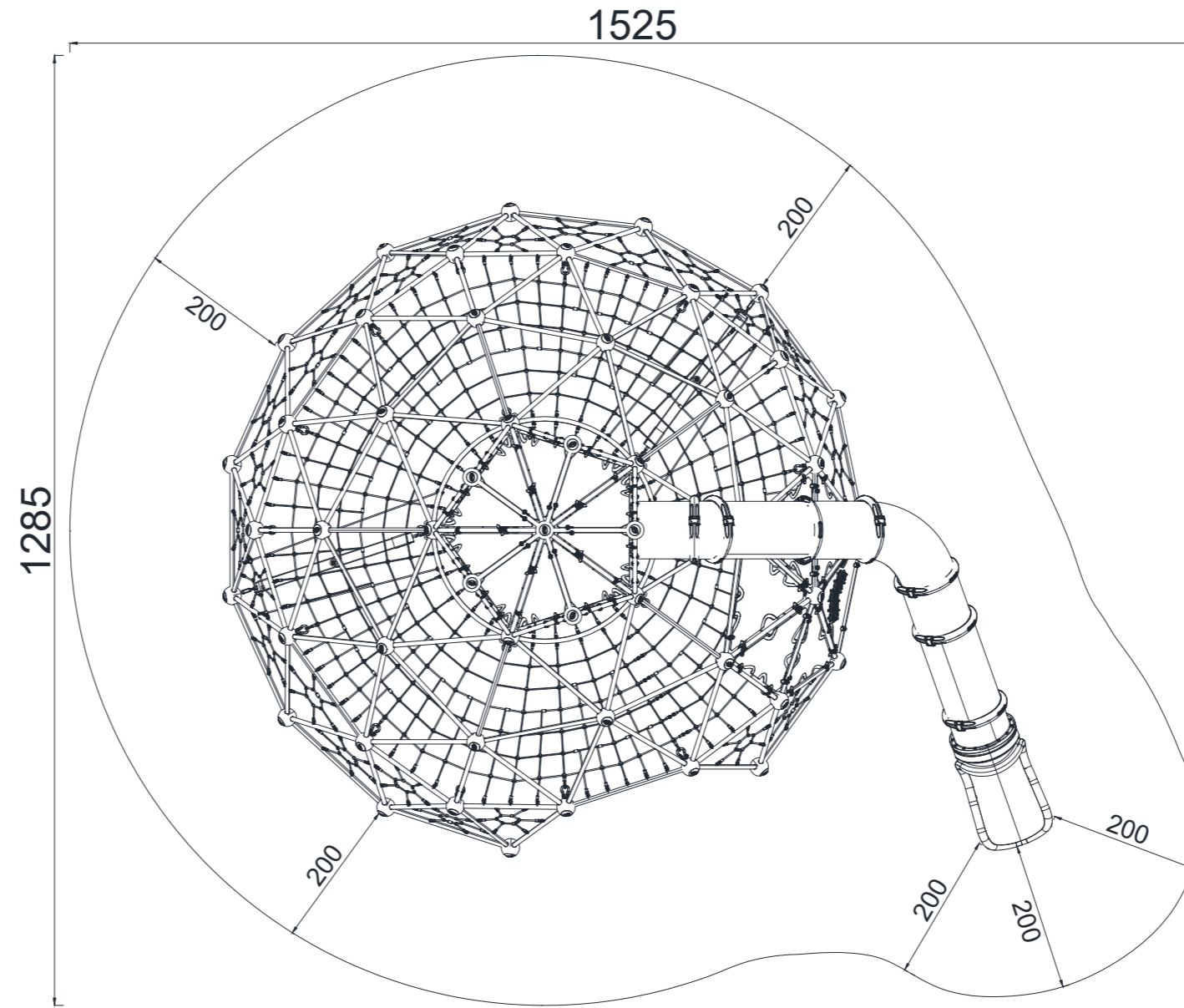
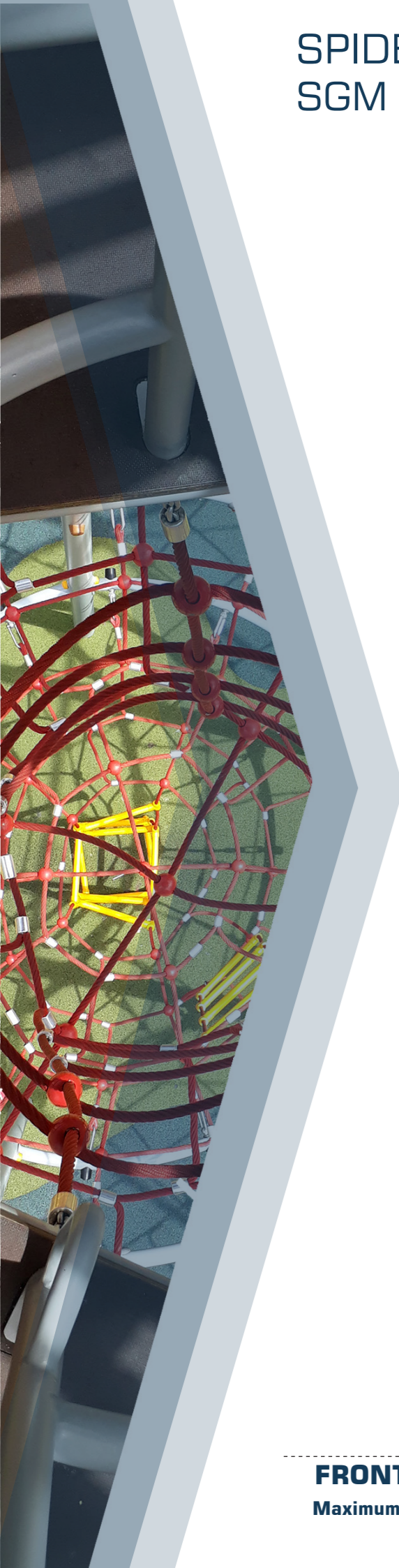

**TOP VIEW**

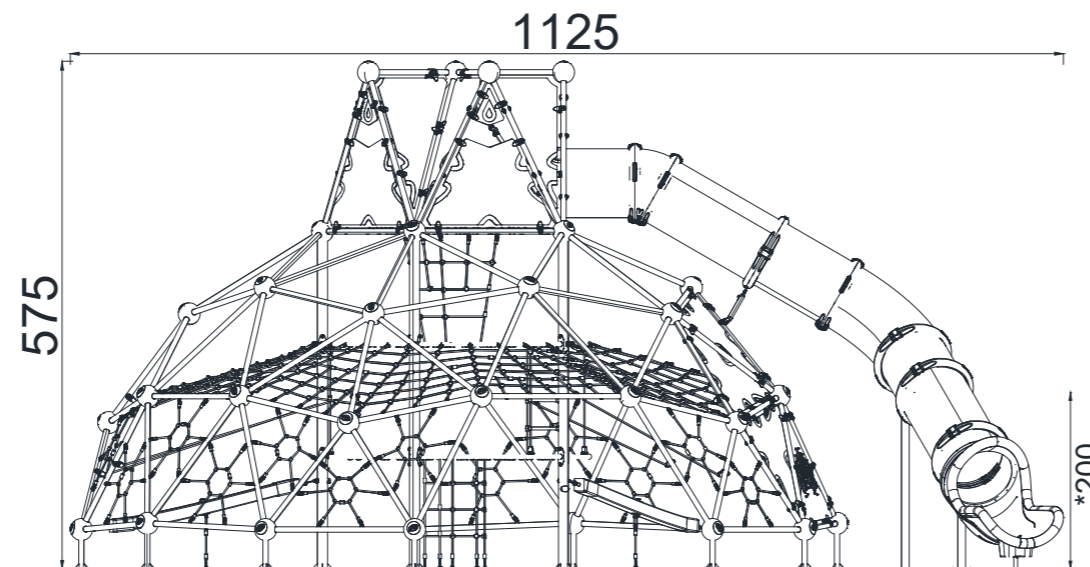

**FRONT VIEW**

Maximum Fall Height / Dimensions shown are in cm

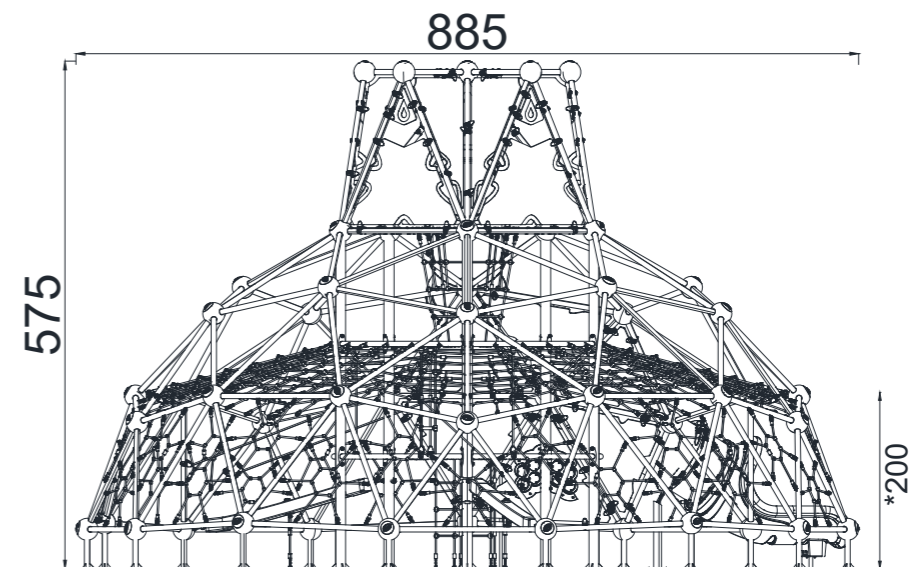

**SIDE VIEW**



**BOUNCING**

To bounce is the act of bouncing on a responsive, flexible, elastic or tensile surface.



**SLIDE**

To slide is the act of moving fast downwards stead on a slide.



**BALANCE**

To balance is to stay upright when walking or standing on a surface that makes this challenging.



**ROCK**

To rock is the action of rocking back and forth, or sideways, on e.g. a piece of spring equipment.



**SITTING**

It is an area where children can rest while sitting and have fun.



**SWING**

To swing is the movement of swinging back forth, of in circular movement, seated, standing or lying, in a unhindered arc.



**HANGING**

To hang in arms is the act of carrying the body with the hands or arms, possible to traverse to another platform or play item.



**SPIN**

To spin involves a fast, repeating horizontal or vertical turn of the body on a piece of equipment that facilitates social interaction.



**CLIMBING**

To climb is the act of moving upwards, cross coordinating arms and legs, on a vertical or inclined surface or net.



**CRAWLING**

To crawl is the movement of moving forwards or backwards, cross - coordinating arms and legs, on a horizontal or slightly incline surface



**RUNNING**

Running is an activity that encourages children to interact with the playgroup by running and develop physically.



**ACCESSIBLE**

Engelli çocukların engelsiz bir biçimde kendilerini farklı hissetmeden oynayabilecekleri özel alanlardır.

These are special areas where children with disabilities can play and have fun and without feeling different.



**INTERACTION**

Çocukların dokunarak, hissederek oyun grubuyla etkileşime geçmesidir.

It is children's communicating with the play group by touching and feeling.



**ROTATE**

Çevirme, vücudun bir ekipman yardımıyla dikey eksende veya daha yavaş tempoyla yatay eksende dönüşünü ifade eder.

To rotate involves a vertical or horizontal slower paced turn of the body, facilitated by a piece of equipment.



**EQUALITY**

Equality is the feature of the playgroup to attract the attention of all children, regardless of gender.



**SOCIALIZE**

To socialize is the act of meeting, communicating or cooperating in an activity that stimulates and facilitates social interaction.



**ROLE PLAY**

Role play is motivated through play items that stage a frame, place or environment for acting out make believe or role play scenarios.



**PULL**

To pull is the act of pulling item towards you or you towards an item with one or both hands, or possibly with the entire body.



**GLIDE**

To glide is the act of moving from one point to another without shifting the feet, in a horizontal or vertical movement in a seated, lying or standing position, letting gravity do the work.



**PUSH**

To push is the act of pushing an item away from you with one or both hands, possibly with the entire body.