

Technical information Denfit Basix - Balance Beam Bars

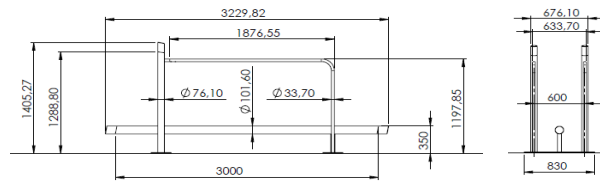
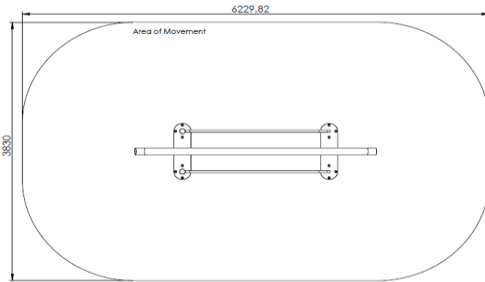
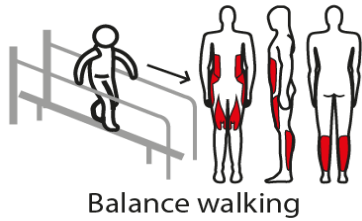
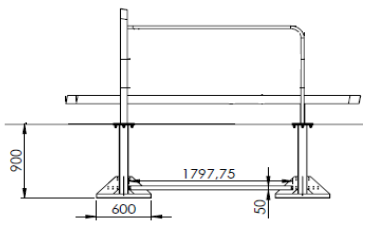
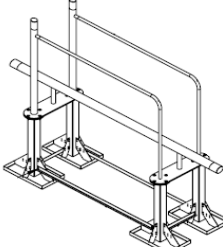
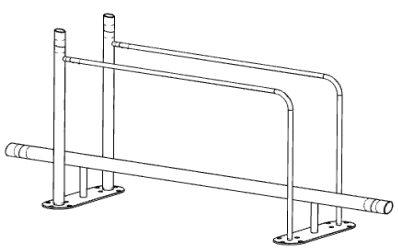

Balance Beam Bars	The basic exercise is Balanced walking, follow the instruction pictogram. Many alternative exercises are possible on the Balance Beam. Check out the QR code that leads to all training possibilities.
Accessories	Sticker with instruction pictogram (as shown in this sheet)
Material	Posts of hot dipped galvanized steel, texture powder coated in Gris Sablé 2400 or Noir Sablé 200 . Tops are polyester powder coated in any RAL colour. Bars of steel, hot dipped galvanized.
Dimensions material:	Posts: \varnothing 48,3 x 2,9 mm Bars: \varnothing 101,6 x 3 mm Tops: \varnothing 101,6 x 3 mm
Area of movement	23,86 m ²
Fall protection	not needed
Weight:	88 kg
Assembly:	Partly preassembled
Free height of fall intended for	350 mm adults and youth > 1400 mm
max. user weight	120 kg
Anchoring	<p>900 mm in the ground No concrete is needed. Only when the ground contains very soft/loose sand concrete is advised for installation.</p>  
	<p>Installation directly on concrete With a foot plate</p> 
Certification:	EN16630:2015 : for permanently installed outdoor fitness equipment
Notice:	<p>Not intended for children <1400 mm The Denfit Basix equipment should not be used if you are suffering from physiological problems. Avoid exaggerated physical exhaustion. In case of doubt please contact your doctor before use. Inspect the equipment before use. Don't use it if it appears damaged or inoperable.</p>