

## Technical information Denfit UrbanGym - BikeFit Senior

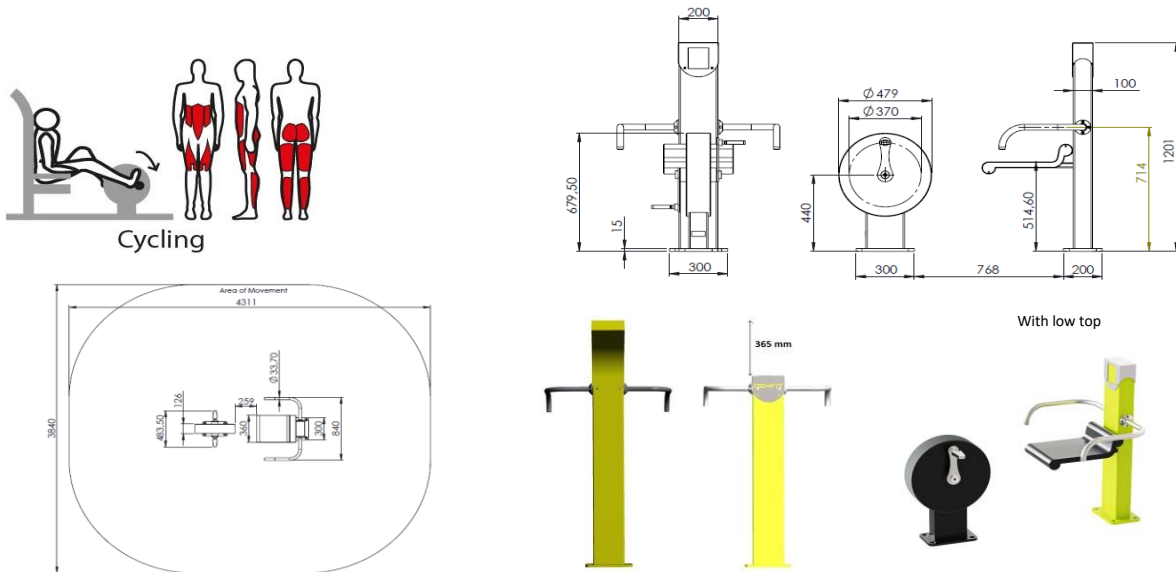
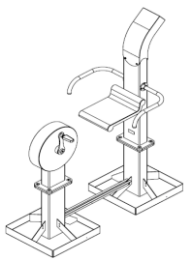
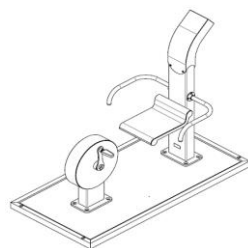
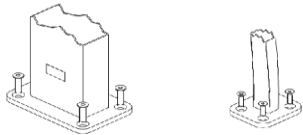

<b>BikeFit</b>	The basic exercise is Cycling, follow the instruction pictogram. Many alternative excersises are possible on the BikeFit. Check out the QR code that leads to all training possibilities.	
<b>Accessories</b>	Instruction pictogram and QR code	
<b>Material</b>	All main posts and seats hot dipped galvanized and powder coated (in many different RAL colours) steel. The bent top is of stainless steel 304 and can be coated in the same color as the post. The strait top is of stainless steel 304, ceramic pearled. Other steel parts hot zinc flame sprayed and textured powder coated in Noir Sablé. Tubes and hand bars stainless steel 304 ceramic pearled. Optional floor is hot dipped galvanized and covered with wet pour in black. The installation frame is of hot dipped galvanized steel.	
<b>Dimensions material</b>	Main post: 200 x 100 x 4 mm Square tubes: 60 x 40 x 3 mm Round tubes/handles: $\varnothing$ 33,7 x 3 mm floor frame: 60 x 40 x 3 mm covered with 10-15 mm wet pour Floor: 1800 x 900 x 60 mm	
<b>Area of movement</b>	16,55 m <sup>2</sup>	
<b>Fall protection</b>	no	
<b>Assembly</b>	Preassembled sections	
<b>Free height of fall</b>	510 mm	
<b>intended for</b>	adults and youth > 1400 mm	
<b>max. user weight</b>	120 kg	
<b>Anchoring</b>	<b>On installation frame in the ground</b> no fluid concrete needed follow the instructions in the service manual 	<b>Installation on own floor frame</b> on soft surface - on concrete - on tarmac follow the instructions in the service manual 
	<b>Installation directly on concrete (not tarmac)</b> installtion without own floor directly on tarmac is not possible follow the instructions in the service manual 	
<b>Certification:</b>	EN 16630-2015: for permanantly installed outdoor fitness equipment	
<b>Notice:</b>	<i>Not intended for children &gt;1400 mm</i> <i>The Denfit Gym equipment should not be used if you are suffering from physiological problems.</i> <i>Avoid exaggerated physical exhaustion. In case of doubt please contact your doctor before use.</i> <i>Inspect the equipment before use. Don't use it if it appears damaged or inoperable.</i>	