

# DYNAMIC GROUP / **COMPACT SERIES**

DGCS 1042A



## Product Information

Dimensions (L x W x H)	: 1,8 x 0,85m
Age Group	: 3+
Capacity	: 4
Fall Height	: 0,7 m
Safety Area	: 11,3 m <sup>2</sup>



## **COMPACT SERIES**

The Compact Series is a product line consisting of a compact module and play station units, each with a theme in itself. The graphics designed in accordance with the theme aim to give children a fairy-tale experience and contribute to their physical development at the same time through climbing and ramps to improve their gross motor skills.

DISTRIBUTED BY



1300 433 364





Metal parts are comprised of ST 37 Steel with a 3-step metal finish. Sandblasting and solvent-free zinc primer coating and electrostatic powder paint application is inherently corrosion resistant under extreme weather conditions and UV.



High quality panels made of HDPE panels are milled to provide a smooth, gently rounded edge. The thickness of the panels varies according to its purpose for floors, roofs, and walls.



UV resistant with high value of light fastness injection technique polyethylene parts are used to grips. It's design has good grip and prevent sweating, making it easy for everyone to use them comfortably.



Spring cross-section diameter is 22 mm, spring diameter 200 mm, and height 400 mm with a maximum of 8 helical turns is one of the best spring manufactured for playgrounds and carries the brand of Eibach™ The product will be manufactured from " cold drawn spring " DH - EN 10270-1 high carbon spring steel.

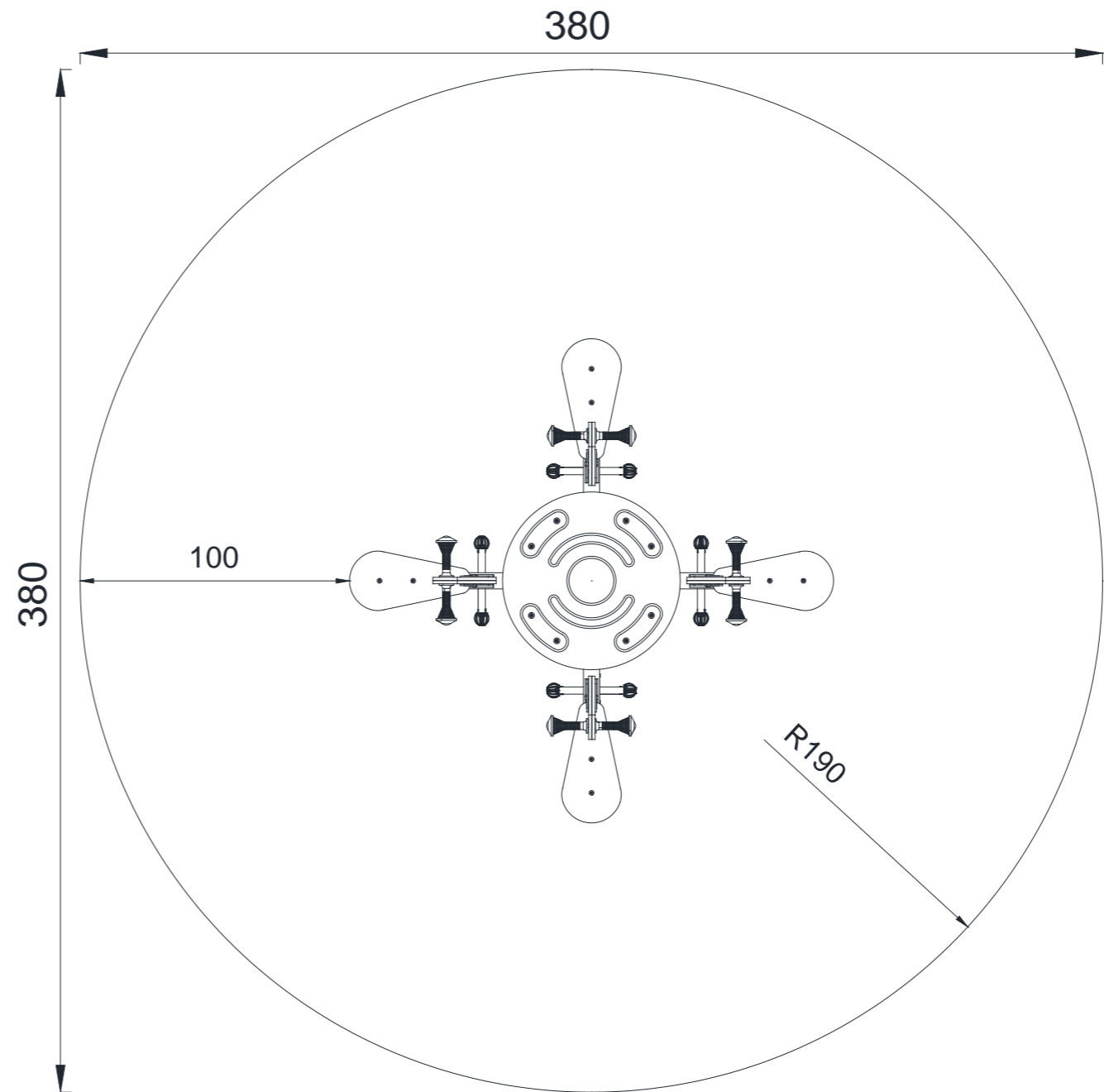

**TOP VIEW**

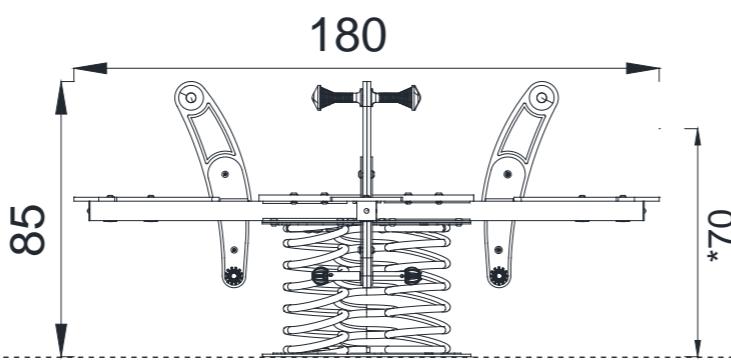

**FRONT VIEW**

Maximum Fall Height / Dimensions shown are in cm

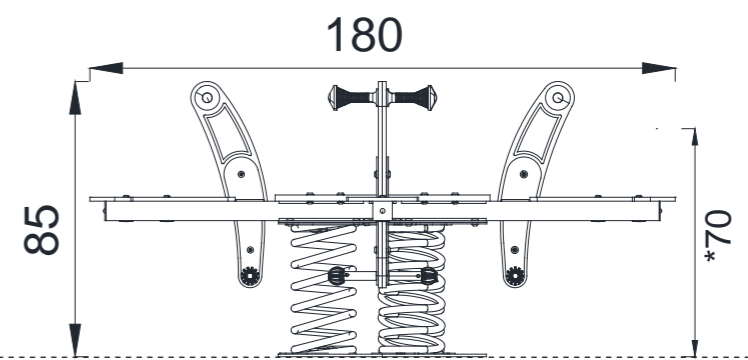

**SIDE VIEW**



## BOUNCING

To bounce is the act of bouncing on a responsive, flexible, elastic or tensile surface.



## SLIDE

To slide is the act of moving fast downwards steady on a slide.



## BALANCE

To balance is to stay upright when walking or standing on a surface that makes this challenging.



## ROCK

To rock is the action of rocking back and forth, or sideways, on e.g. a piece of spring equipment.



## SITTING

It is an area where children can rest while sitting and have fun.



## SWING

To swing is the movement of swinging back forth, of in circular movement, seated, standing or lying, in an unhindered arc.



## HANGING

To hang in arms is the act of carrying the body with the hands or arms, possible to traverse to another platform or play item.



## SPIN

To spin involves a fast, repeating horizontal or vertical turn of the body on a piece of equipment that facilitates social interaction.



## CLIMBING

To climb is the act of moving upwards, cross coordinating arms and legs, on a vertical or inclined surface or net.



## CRAWLING

To crawl is the movement of moving forwards or backwards, cross-coordinating arms and legs, on a horizontal or slightly incline surface



## RUNNING

Running is an activity that encourages children to interact with the playgroup by running and develop physically.



## ACCESSIBLE

These are special areas where children with disabilities can play and have fun and without feeling different.



## INTERACTION

It is children's communicating with the play group by touching and feeling.



## ROTATE

To rotate involves a vertical or horizontal slower paced turn of the body, facilitated by a piece of equipment.



## EQUALITY

Equality is the feature of the playgroup to attract the attention of all children, regardless of gender.



## SOCIALIZE

To socialize is the act of meeting, communicating or cooperating in an activity that stimulates and facilitates social interaction.



## ROLE PLAY

Role play is motivated through play items that stage a frame, place or environment for acting out make believe or role play scenarios.



## PULL

To pull is the act of pulling item towards you or you towards an item with one or both hands, or possibly with the entire body.



## GLIDE

To glide is the act of moving from one point to another without shifting the feet, in a horizontal or vertical movement in a seated, lying or standing position, letting gravity do the work.



## PUSH

To push is the act of pushing an item away from you with one or both hands, possibly with the entire body.