

MODULAR CLIMBING / ASTERO CLIMBING SERIES

DGHS 111



Product Information

Dimensions (L x W x H)	: 3,9 x 3,8 x 1,4m
Age Group	: 5+
Capacity	: 10
Fall Height	: 1,4 m
Safety Area	: 34,6 m ²

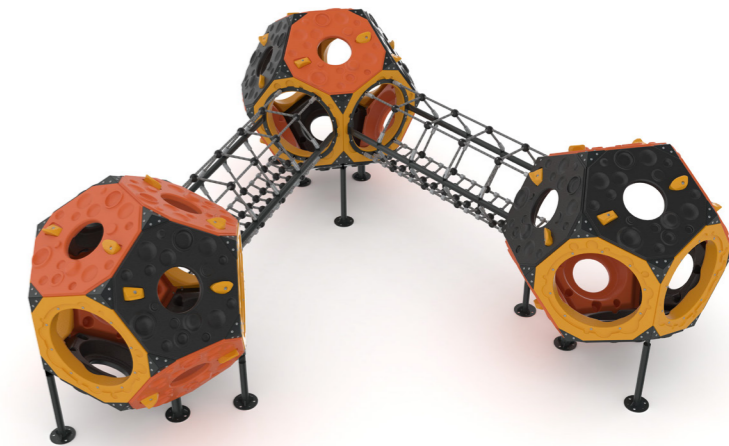
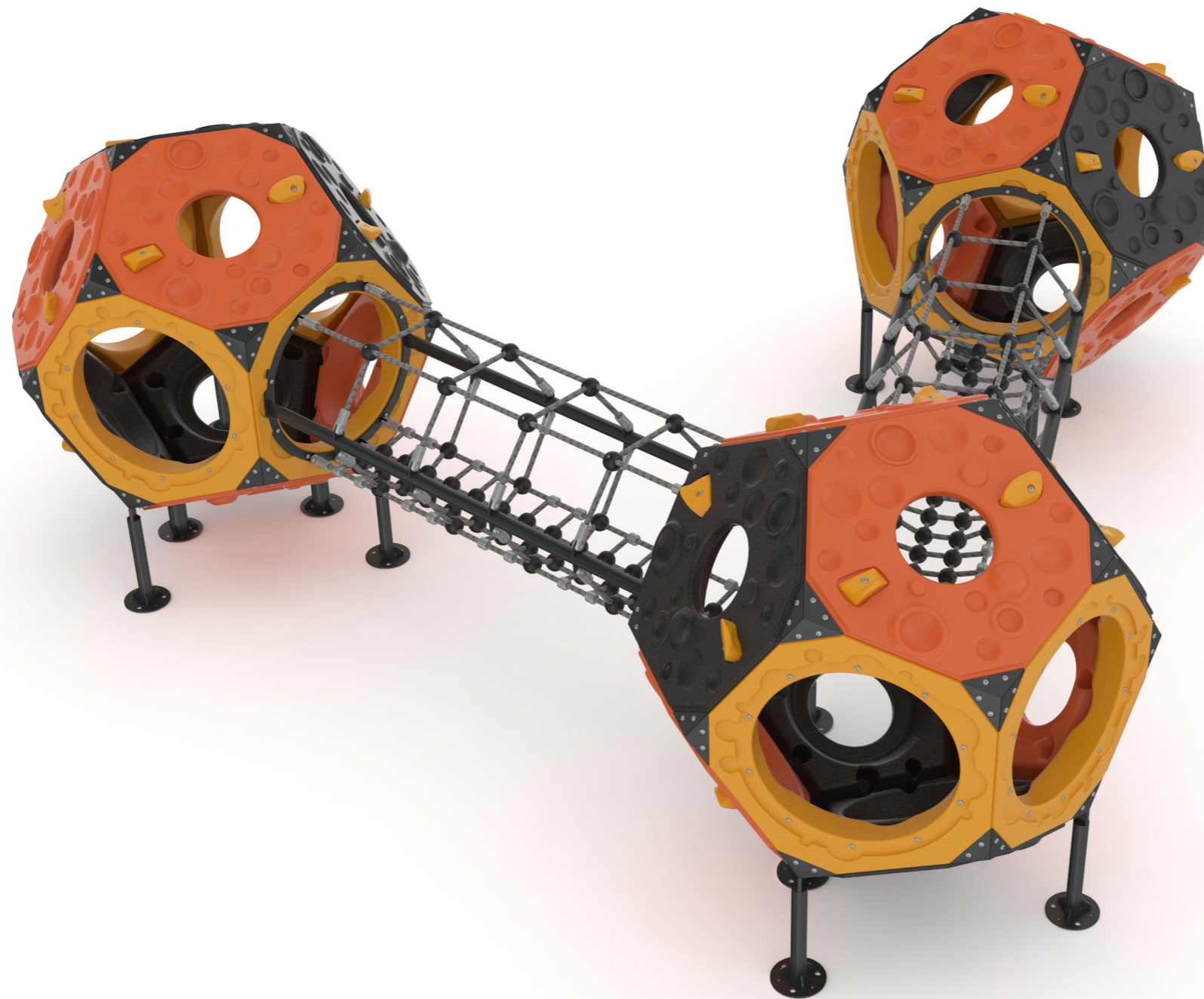

ASTERO CLIMBING

The Astero climbing is a large polygonal climbing unit consisting of two polyethylene body components and a metal fitting. Astero units can be differentiated by positioning multiple blocks on top of each other or side by side, furthermore, net bridges can be added as passage. It helps children socialize while having fun and play together. While the climbing experience, which gradually becomes difficult thanks to the different elevations created by the units, contributes to the development of their physical skills, it is aimed that children create and play their own games in the areas formed within the modules.

DISTRIBUTED BY



1300 433 364





UV resistant with high value of light fastness rotomolded polyethylene parts are used to form the structure. All parts are manufactured with double wall technique with the thickness between 4-6 mm.

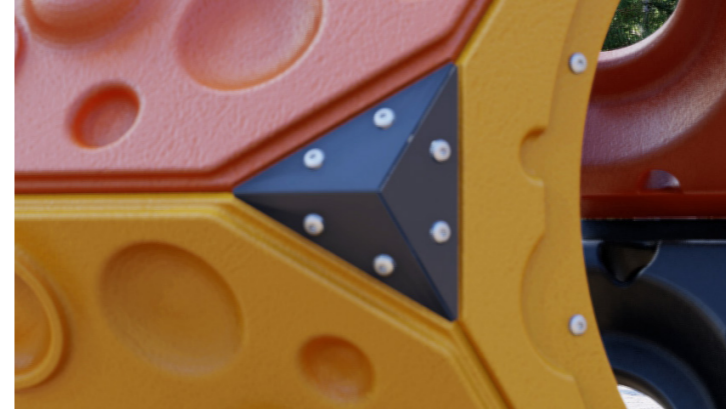

Metal pipes and other metal parts are comprised of ST 37 Steel with Metal finish; Sandblasting and treated with solvent-free zinc primer coating which is inherently corrosion resisted under extreme weather conditions and UV.



Single-casing, injection manufactured connectors are used at the intersection points of ropes.



CmrRope™ is formed by 6 strands of galvanized wires and a core either steel or fiber. Each strand is tightly braided with Polyester which is adhered to galvanized wires with a patented method to create a solid surface where polyester meets with wires. So extra protection is achieved against friction and vandalism. Surface is extremely abrasion and UV resistant also fire retardant.

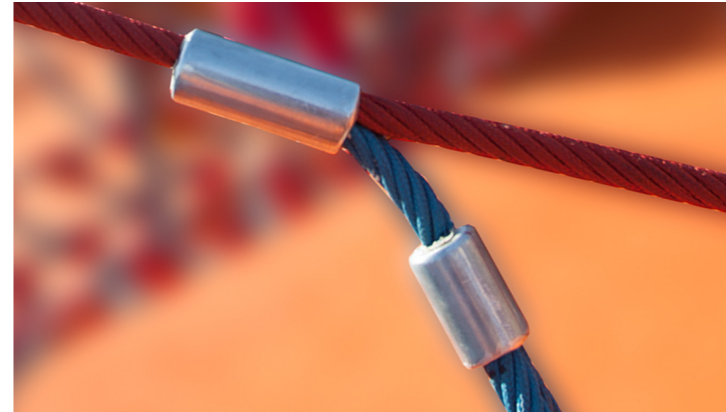

Tek parça alüminyum döküm konektörler, ipin hareket etmesini ve erken aşınmayı önlemek için 300 ton pres ile sıkıştırılmıştır. "Sonlandırıcı konektör" keskin açı veya kenarlar bulundurmaz ve iyi bir kavrama sunar. Bu konektörlerin ana çerçeveye bağlantısı kaynaklı flanşlar ya da "C" alüminyum kelepçelerle yapılır.

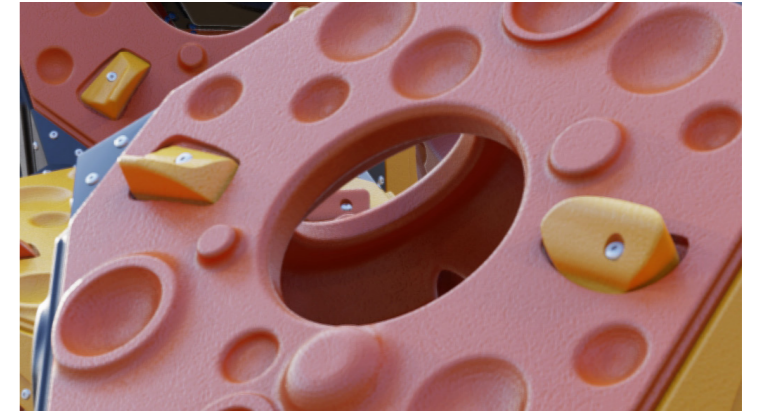

Make of ultra-durable epoxy technology and textured surface easy to grasp firmly. Perfect shapes and sizes designed for users, easy and comfortable to hold. Suitable for indoor and outdoor, make a great addition to climbing walls and playgrounds. Grips shall be sized for different models like S,M,L,XL. Easy to install. Provide balance flexibility and endurance while having fun. Handles are manufactured following European EN 12572 standards.

ASTERO CLIMBING SERIES DGHS 111

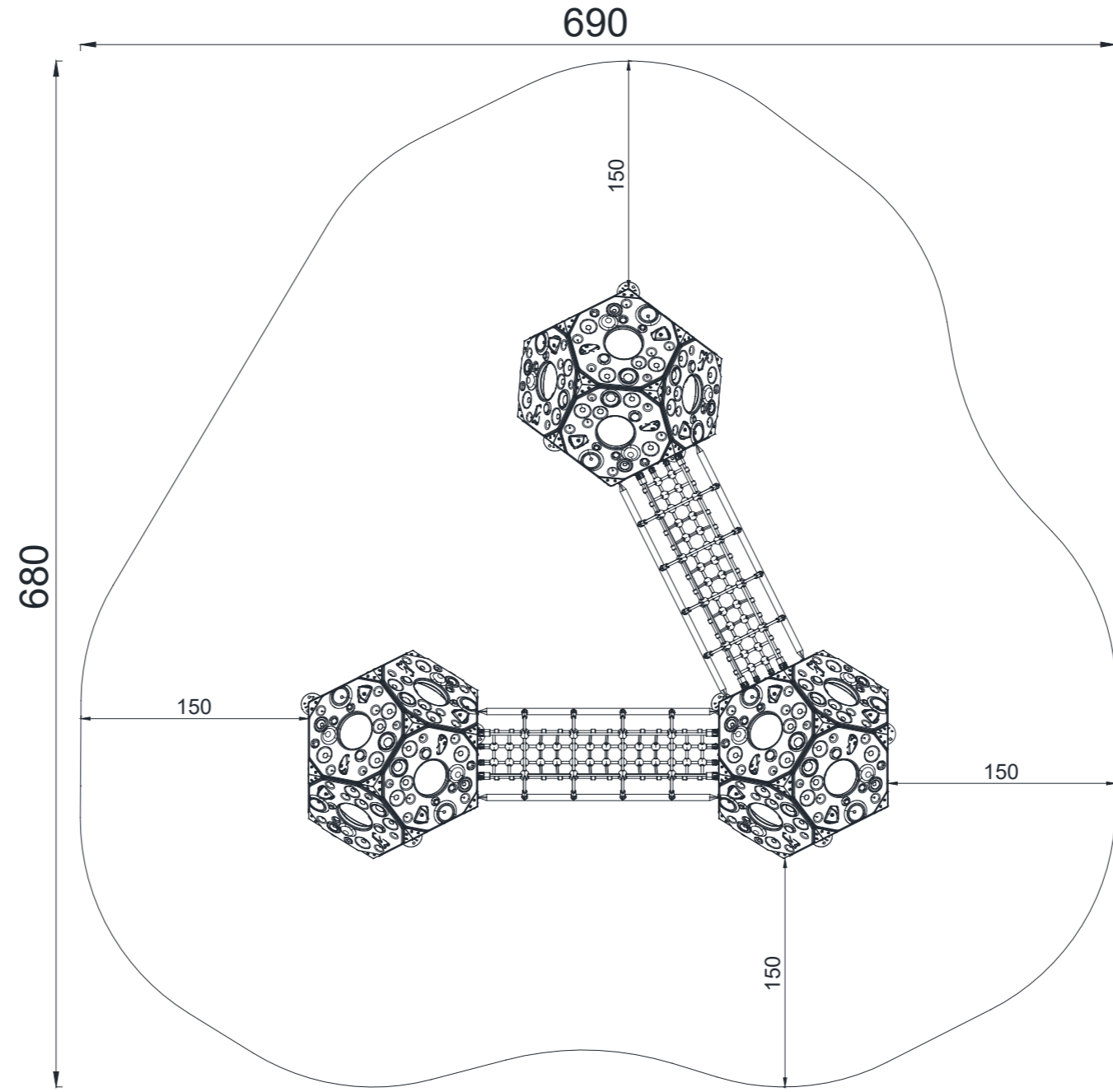
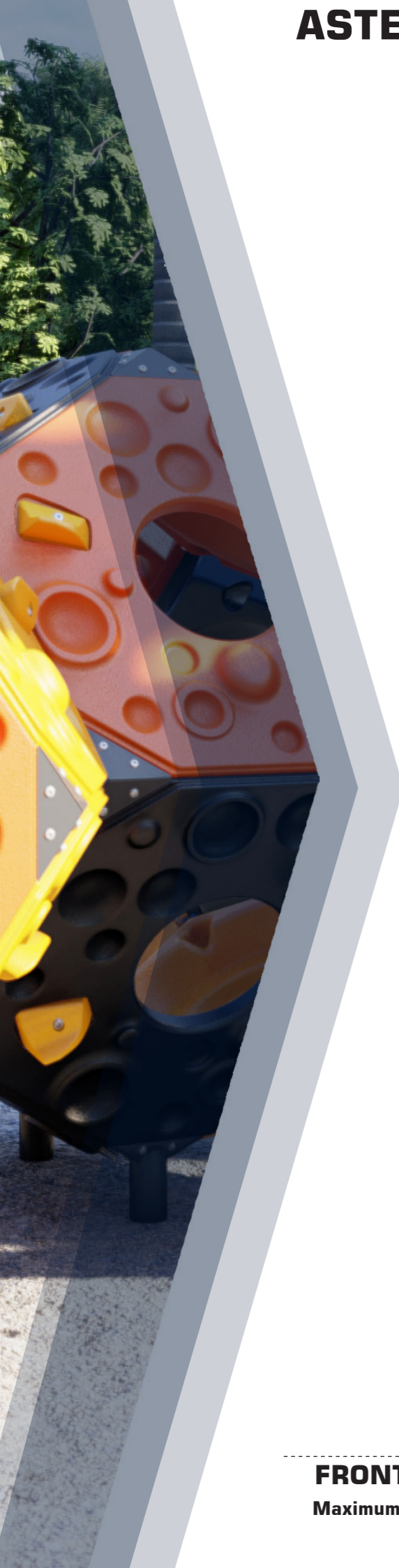

TOP VIEW

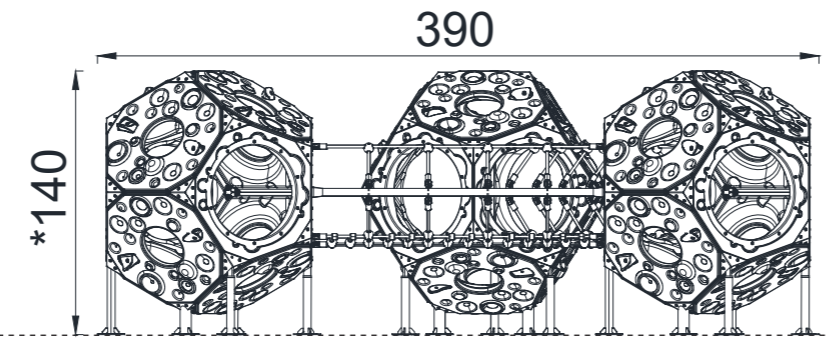

FRONT VIEW

Maximum Fall Height / Dimensions shown are in cm

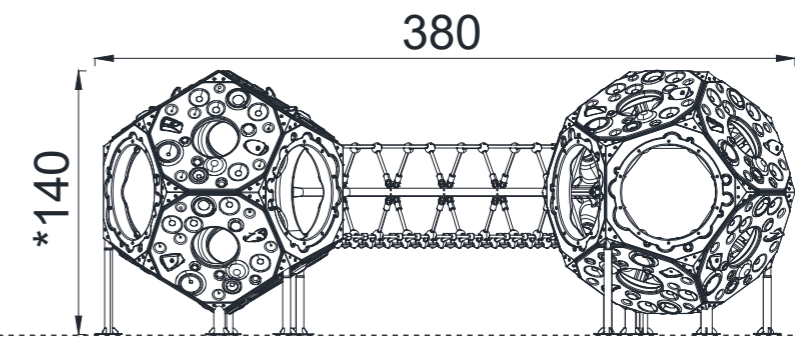

SIDE VIEW



BOUNCING

To bounce is the act of bouncing on a responsive, flexible, elastic or tensile surface.



SLIDE

To slide is the act of moving fast downwards steadily on a slide.



BALANCE

To balance is to stay upright when walking or standing on a surface that makes this challenging.



ROCK

To rock is the action of rocking back and forth, or sideways, on e.g. a piece of spring equipment.



SITTING

It is an area where children can rest while sitting and have fun.



SWING

To swing is the movement of swinging back forth, or in circular movement, seated, standing or lying, in an unhindered arc.



HANGING

To hang in arms is the act of carrying the body with the hands or arms, possible to traverse to another platform or play item.



SPIN

To spin involves a fast, repeating horizontal or vertical turn of the body on a piece of equipment that facilitates social interaction.



CLIMBING

To climb is the act of moving upwards, cross coordinating arms and legs, on a vertical or inclined surface or net.



CRAWLING

To crawl is the movement of moving forwards or backwards, cross-coordinating arms and legs, on a horizontal or slightly inclined surface.



RUNNING

Running is an activity that encourages children to interact with the playgroup by running and develop physically.



ACCESSIBLE

These are special areas where children with disabilities can play and have fun and without feeling different.



INTERACTION

It is children's communicating with the play group by touching and feeling.



ROTATE

To rotate involves a vertical or horizontal slower paced turn of the body, facilitated by a piece of equipment.



EQUALITY

Equality is the feature of the playgroup to attract the attention of all children, regardless of gender.



SOCIALIZE

To socialize is the act of meeting, communicating or cooperating in an activity that stimulates and facilitates social interaction.



ROLE PLAY

Role play is motivated through play items that stage a frame, place or environment for acting out make-believe or role-play scenarios.



PULL

To pull is the act of pulling an item towards you or you towards an item with one or both hands, or possibly with the entire body.



GLIDE

To glide is the act of moving from one point to another without shifting the feet, in a horizontal or vertical movement in a seated, lying or standing position, letting gravity do the work.



PUSH

To push is the act of pushing an item away from you with one or both hands, possibly with the entire body.