



Product Information

Dimensions (W x L x H) :	11,55 x 7,35 x 4,1m
Age Group :	5+
Capacity :	34
Rubber Surface Fall Height :	1,9 m
Loose Surface Fall Height :	1,6 m
Rubber Surface Safety Area :	130,6 m ²
Loose Surface Safety Area :	111,5 m ²



Metal Renkleri/Metal Colours			İp Renkleri/Rope Colours	
RAL 3020	RAL 5001	RAL 5024	C 750	C 850
RAL 6011	RAL 7021	RAL 7040	C 591	C 662
RAL 8002			C 332	C 905

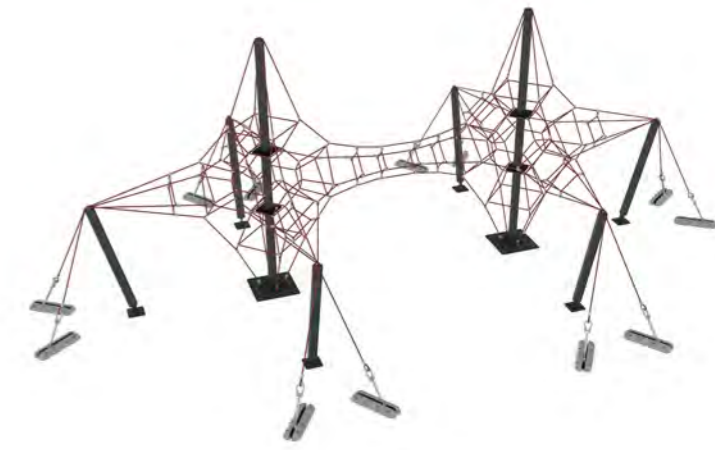

SPIDER GROUP

Spider Group takes you to the excitement of climbing and the peaks of entertainment.

It was designed to allow children to experience the thrill of climbing while supporting improvement of the physical skills that will contribute to the development of the muscle-coordination system. It creates a target for children to climb, allows them to overcome fear of heights. It also contributes to the mental development of children while choosing the path they climb.

DISTRIBUTED BY



1300 433 364



Metal pipes and other metal parts are comprised of ST 37 Steel with Metal finish; Sandblasting and treated with solvent-free zinc primer coating which is inherently corrosion resisted under extreme weather conditions and UV.



Mats shall be 3-layer textile-reinforced flexible rubber and they are fixed to armed ropes with polyamide connectors either to close entrapments or to create seats and trampolines.



Single-casing aluminum cast caps have bedding channels in the cover system to keep the rope tight and stable.



CmrRope™ is formed by 6 strands of galvanized wires and a core either steel or fiber. Each strand is tightly braided with Polyester which is adhered to galvanized wires with a patented method to create a solid surface where polyester meets with wires. So extra protection is achieved against friction and vandalism. Surface is extremely abrasion and UV resistant also fire retardant.



Sandblasted – solvent free zinc primer treated, and powder coated ST 37 metal anchor contains multiple connection points to allow adjusting and connection of the safety rope. For main mast, a cocoon shall be placed in the center. This two parts assembly allows less pressure to cocoon edges and easier installation. Corner anchors are covered with rotomolded polyethylene covers.



Single-casing aluminum cast connectors are compressed with 300 tons to avoid moving and premature wear. “E (end stop) connector” is shapely and pleasant to grip with no sharp angles or edges. These connectors are fastened to main frame either to welded flanges on main frame or with “C” aluminum clamps to main frame.



RUBBER SURFACE

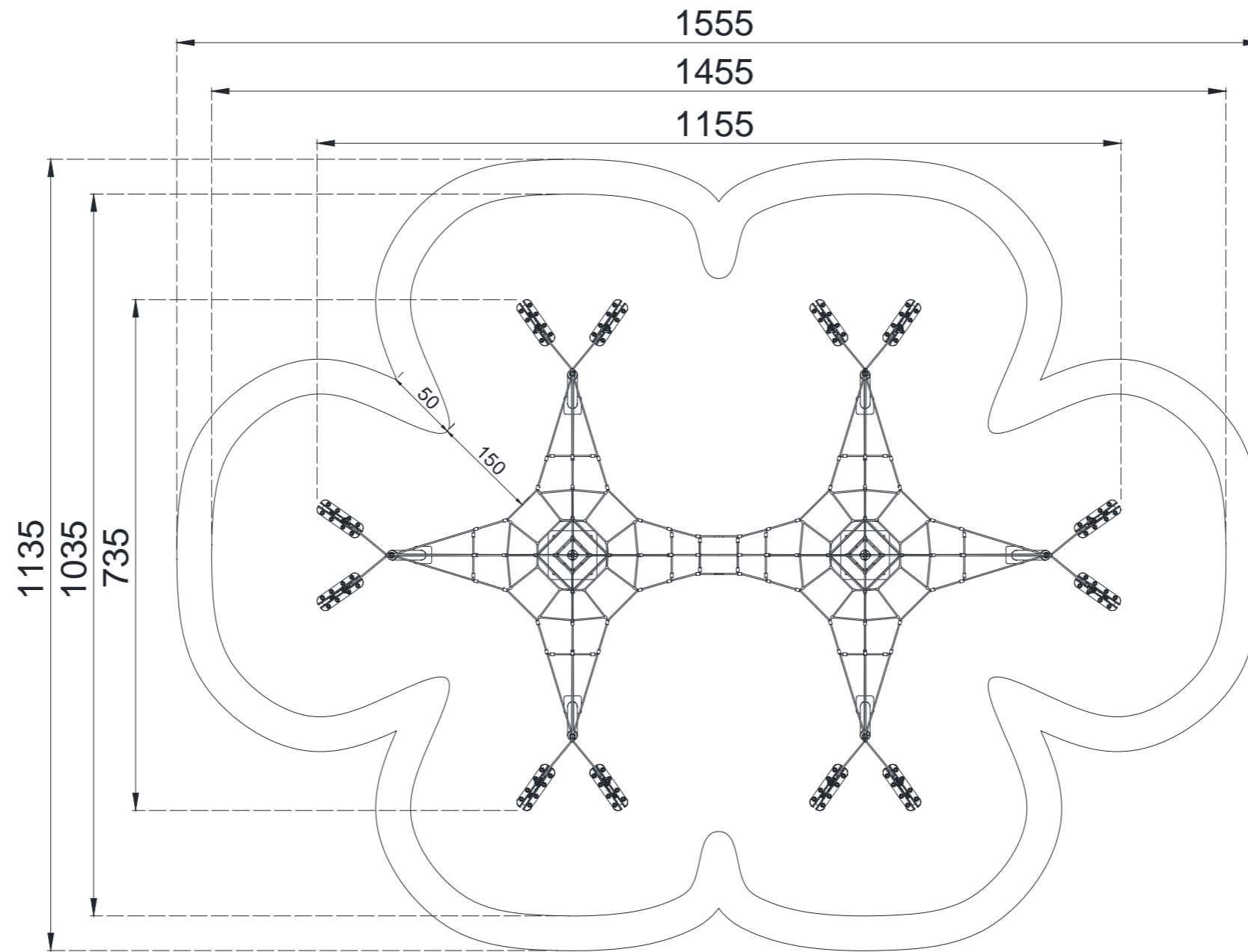

TOP VIEW

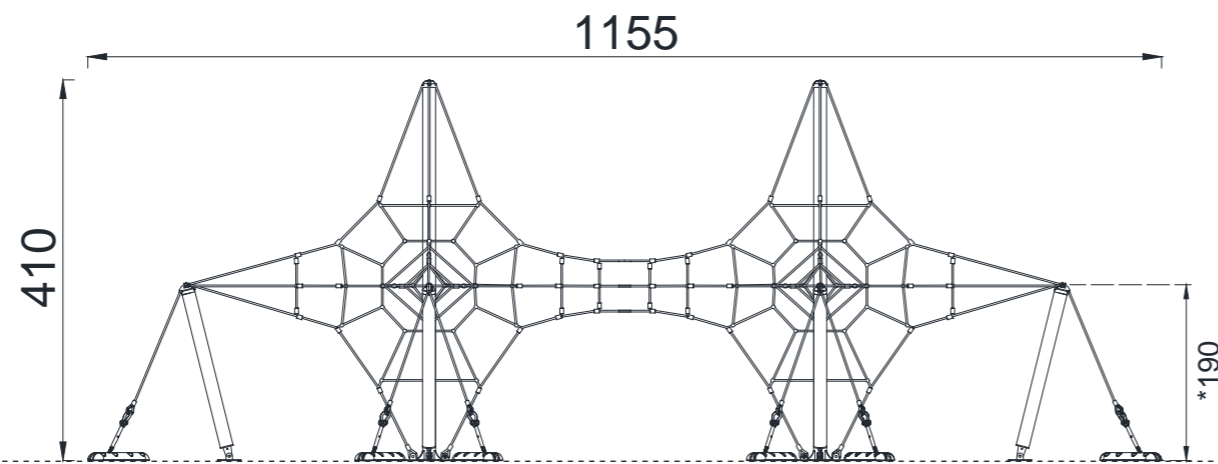

FRONT VIEW

Maximum Fall Height / Dimensions shown are in cm

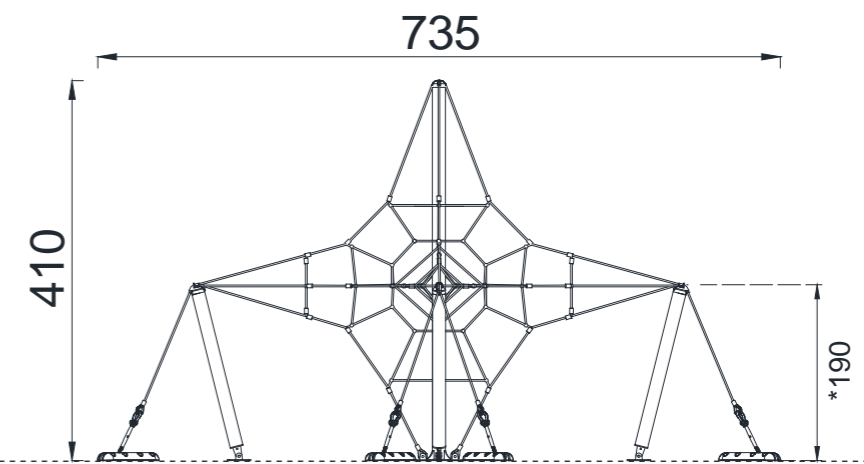

SIDE VIEW

LOOSE SURFACE

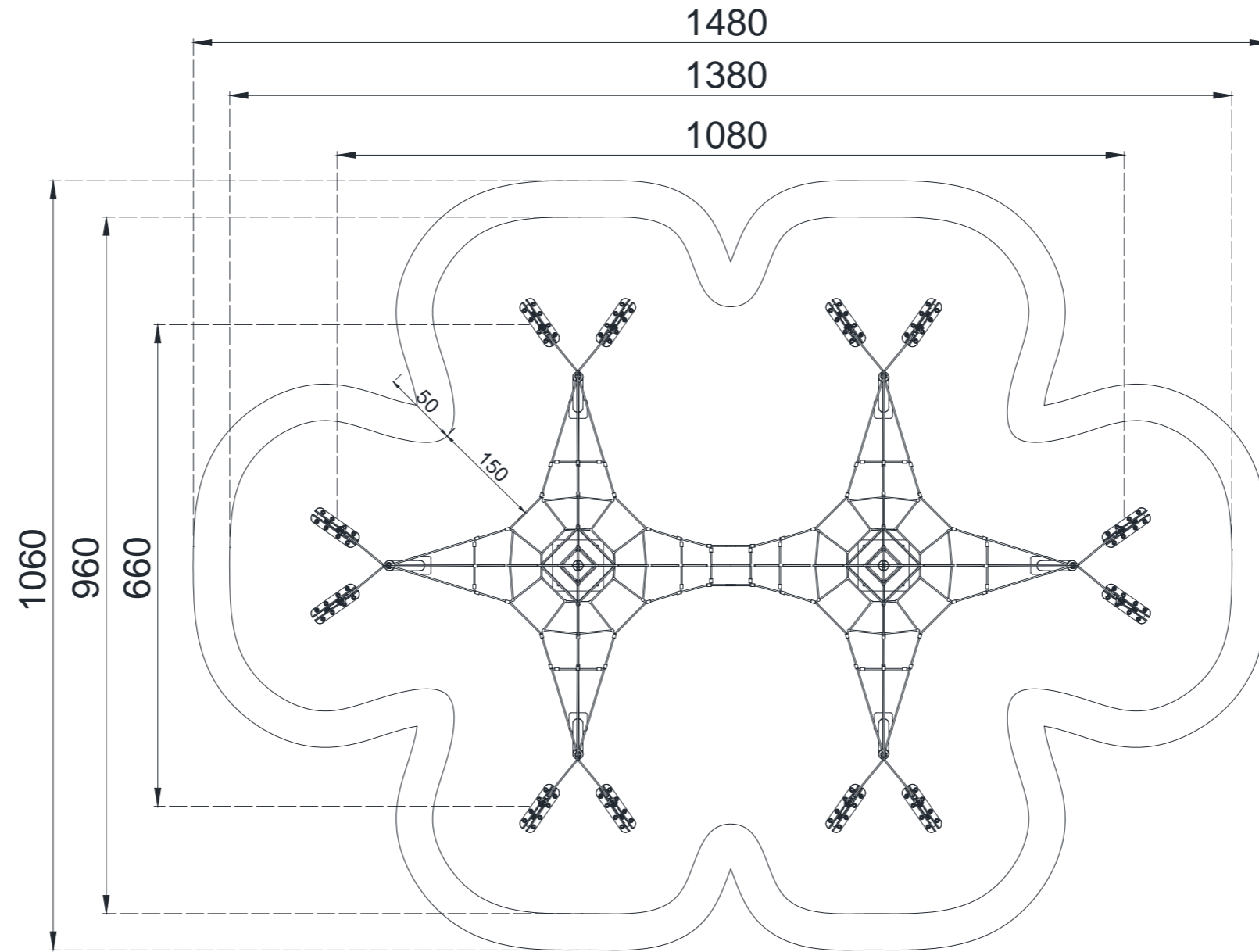

TOP VIEW

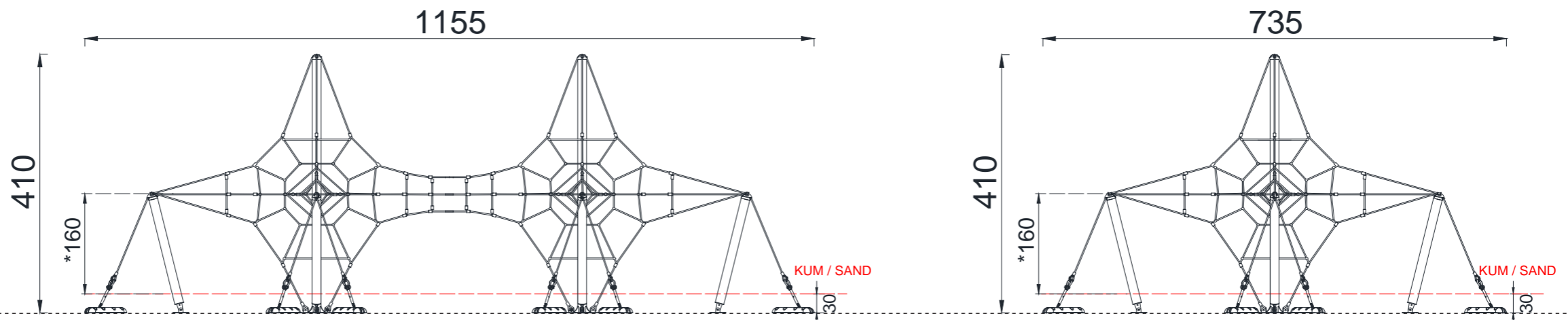

FRONT VIEW

Maximum Fall Height / Dimensions shown are in cm

SIDE VIEW



BOUNCING

To bounce is the act of bouncing on a responsive, flexible, elastic or tensile surface.



SLIDE

To slide is the act of moving fast downwards steady on a slide.



BALANCE

To balance is to stay upright when walking or standing on a surface that makes this challenging.



SALINIM / ROCK

To rock is the action of rocking back and forth, or sideways, on e.g. a piece of spring equipment.



SITTING

It is an area where children can rest while sitting and have fun.



SWING

To swing is the movement of swinging back forth, or in circular movement, seated, standing or lying, in an unhindered arc.



HANGING

To hang in arms is the act of carrying the body with the hands or arms, possible to traverse to another platform or play item.



SPIN

To spin involves a fast, repeating horizontal or vertical turn of the body on a piece of equipment that facilitates social interaction.



CLIMBING

To climb is the act of moving upwards, cross coordinating arms and legs, on a vertical or inclined surface or net.



CRAWLING

To crawl is the movement of moving forwards or backwards, cross-coordinating arms and legs, on a horizontal or slightly incline surface



RUNNING

Running is an activity that encourages children to interact with the playgroup by running and develop physically.



ACCESSIBLE

These are special areas where children with disabilities can play and have fun and without feeling different.



INTERACTION

It is children's communicating with the play group by touching and feeling.



ROTATE

To rotate involves a vertical or horizontal slower paced turn of the body, facilitated by a piece of equipment.



EQUALITY

Equality is the feature of the playgroup to attract the attention of all children, regardless of gender.



SOSYALLEŞME / SOCIALIZE

To socialize is the act of meeting, communicating or cooperating in an activity that stimulates and facilitates social interaction.



ROL YAPMA / ROLE PLAY

Role play is motivated through play items that stage a frame, place or environment for acting out make believe or role play scenarios.



ÇEKME / PULL

To pull is the act of pulling item towards you or you towards an item with one or both hands, or possibly with the entire body.



SÜZÜLME / GLIDE

To glide is the act of moving from one point to another without shifting the feet, in a horizontal or vertical movement in a seated, lying or standing position, letting gravity do the work.



İTME / PUSH

To push is the act of pushing an item away from you with one or both hands, possibly with the entire body.