

THIS DRAWING IS INDICATIVE ONLY

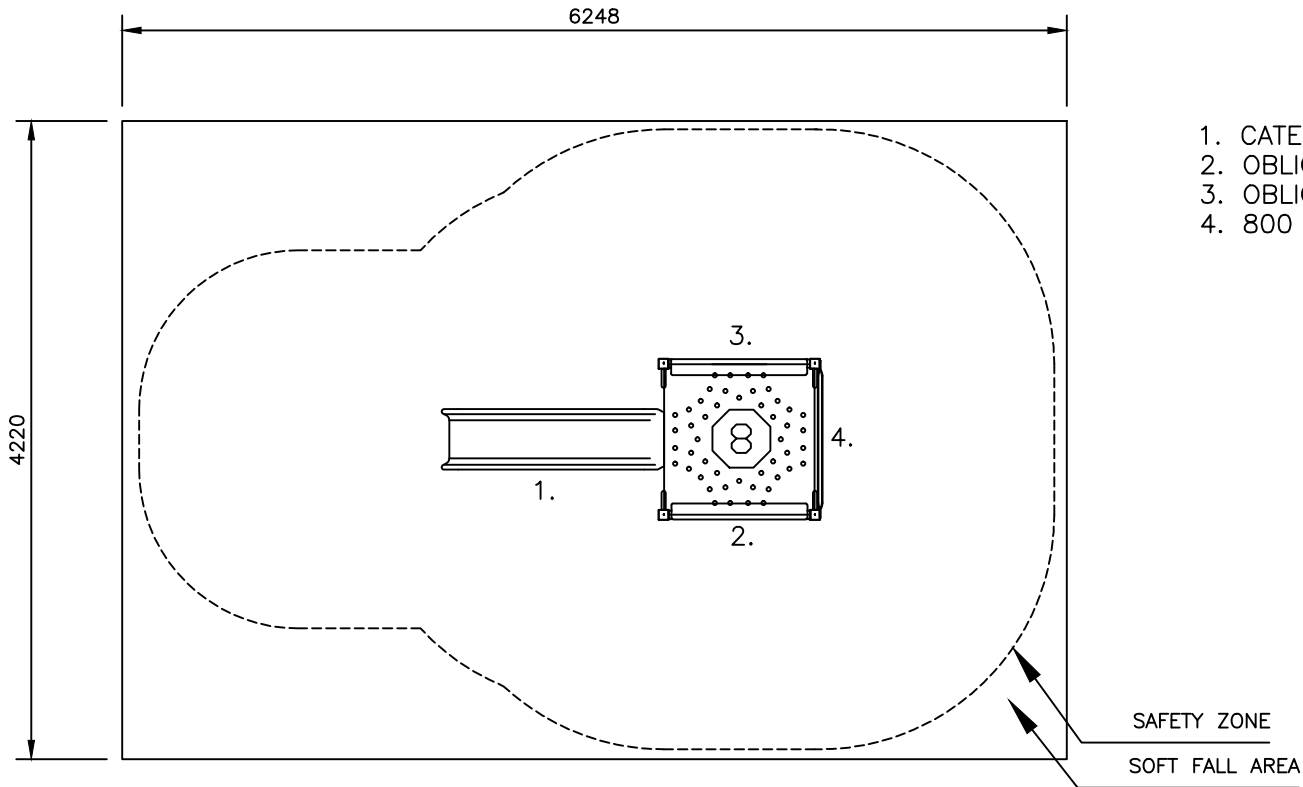

1. CATERPILLAR SLIDE 800
2. OBLIQUE PANEL
3. OBLIQUE PANEL
4. 800 RAIL LADDER

SLDP2014-800 FREESTANDING SLIDE
MAX FHF: 0.8M

DO NOT SCALE

SAFETY ZONE
SOFT FALL AREA

SCALE = mm

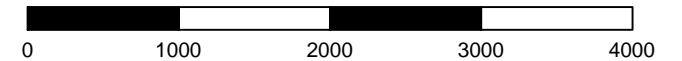

APPROX AREA (sq.m.):26.4 APPROX PERIMETER (lin.m.):20.9

FREESTANDING SLIDE
800 CATERPILLAR
STANDARD DRAWING

DRAWING No.:SLDP2014 REV: A

DRN: R. CROOKE SCALE 1:50 SIZE
DATE: 12/09/17 SHEET 1 OF 1 A4

- Heights above Playground surface are shown on decks and all play equipment, is. Ⓢ = 400mm
- Impact absorbing ground cover is required under and around all play equipment.
- The min. recommended fall zone around the entire play structure is shown. This zone is to be free of all tripping or collision hazards (ie. roots, rocks, border material, etc).
- Site layout and dimensions are subject to verification prior to installation.
- Dimensions in millimetres unless stated otherwise.

